



BALLOMAX[®]

DESIGNED TO LAST



SECTION 8

High temperature valves

Reduced bore

High temperature valve - DN10-50, PN40

Type 55100 - Reduced bore

Female x Female

Fully welded steel ball valve.

Materials

See next page.

Applications

Isolating valve for steam systems. In case of demand for valves for systems with pressure and temperature outside defined range - please contact BROEN.

Media

Water and steam. Other media on request. If in doubt, please contact BROEN Ballomax® Sales Department.

Surface treatment

Eco-friendly protection finish against corrosion.

Operation

The standard handle is 180 degrees adjustable.

Approvals and certificates

BROEN is certified according to ISO 9001 and environmentally certified according to ISO 14001. BROEN Ballomax® is approved according to the requirements of Pressure Equipment Directive (PED). All ball valves as from DN40 are CE-marked. The 3.1 certificate is available upon request.

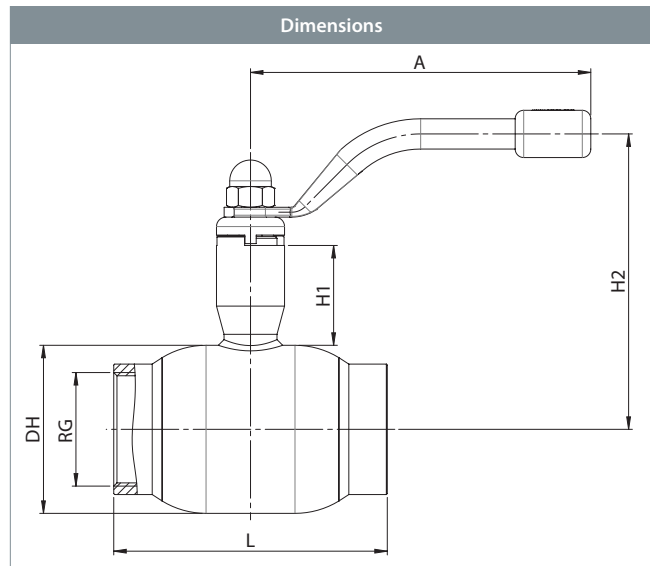

DN	BROEN No.	Bore	Kvs	net Weight kg	All dimensions in mm					
					RG	DH	L	H1	H2	A
10	5510040010 010	10	7	0.6	3/8"	38.0	65	42	104	140
15	5510040015 010	10	8	0.6	1/2"	38.0	65	42	104	140
20	5510040020 010	15	15	0.7	3/4"	42.4	75	44	107	140
25	5510040025 010	20	27	0.8	1"	51.0	90	44	112	140
32	5510040032 010	25	40	1.2	1 1/4"	57.0	105	45	116	140
40	5510040040 010	32	69	2.1	1 1/2"	76.1	120	68	150	180
50	5510040050 010	40	110	2.9	2"	88.9	145	68	156	180

High temperature valve - DN10-50, PN40

Type 55100 - Reduced bore



Technical drawing		Material description	
	3	Female	Steel - S355J2+N / 1.0570 / EN 10025-2
	5	Valve body	Steel - P235GH / 1.0345 / EN 10217-2
	6	Ball	Stainless steel - AISI304L / 1.4306 / EN 10217-7
	7	Seat ring	PTFE 20% Carbon
	8	Back-up ring	Steel - DC01 / 1.0330 / EN 10130
	9	Disc spring	Steel - C75S / 1.1248 / EN 10132-4
	11	Stem guide	Steel - S355J2+N / 1.0570 / EN 10025-2
	12	Stem	Stainless steel - ASTM420 / 1.4021 / EN 10088-3
	13	Stem washer	Stainless steel - AISI304 / 1.4301 / EN 10088-3
	14	Friction washer	PTFE 20% Carbon
	20	Handle	Steel
	21	Cap nut	Steel - galvanized
	43	Endplate	Steel - S235JRG2 / 1.0038 / EN 10025-2
	44	Threaded bush	Stainless steel - AISI303 / 1.4305 / EN 10088-3
45	Brass ring	Brass B10	
46	Stem gasket	Graphite	

High temperature valve - DN10-50, PN40

Type 55100 - Reduced bore

Female x Female with ISO-flange

Fully welded steel ball valve.

Materials

See next page.

Applications

Isolating valve for steam systems. In case of demand for valves for systems with pressure and temperature outside defined range - please contact BROEN.

Media

Water and steam. Other media on request. If in doubt, please contact BROEN Ballomax® Sales Department.

Surface treatment

Eco-friendly protection finish against corrosion.

Operation

The standard handle is 180 degrees adjustable.

Approvals and certificates

BROEN is certified according to ISO 9001 and environmentally certified according to ISO 14001. BROEN Ballomax® is approved according to the requirements of Pressure Equipment Directive (PED). All ball valves as from DN40 are CE-marked. The 3.1 certificate is available upon request.

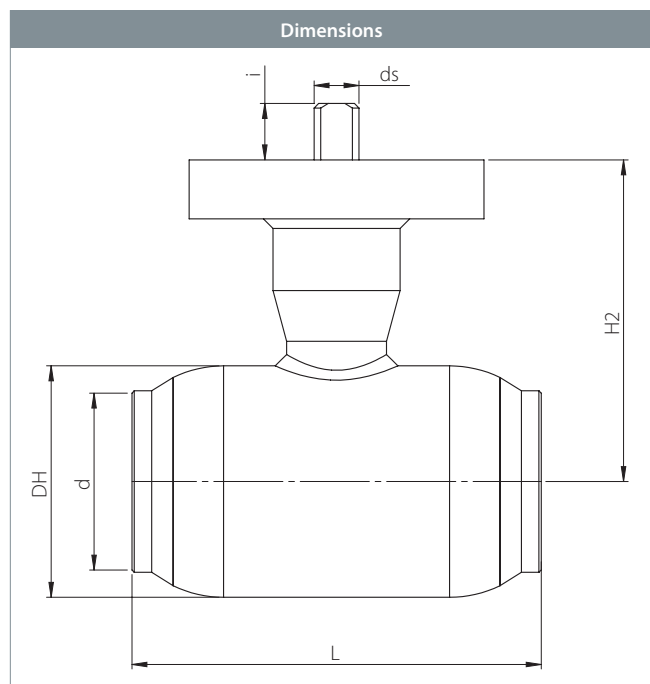

DN	BROEN No.	Bore	Kvs	net Weight kg	All dimensions in mm						
					d	DH	L	H2	ds	i	ISO
10	5510040010 300	10	7	0.7	3/8"	38.0	65	63	10	12.5	F5
15	5510040015 300	10	8	0.7	1/2"	38.0	65	63	10	12.5	F5
20	5510040020 300	15	15	0.8	3/4"	42.4	75	67	10	12.5	F5
25	5510040025 300	20	27	0.9	1"	51.0	90	71	10	12.5	F5
32	5510040032 300	25	40	1.3	1 1/4"	57.0	105	75	10	12.5	F5
40	5510040040 300	32	69	2.2	1 1/2"	76.1	120	106	14	18.0	F7
50	5510040050 300	40	110	3.0	2"	88.9	145	112	14	18.0	F7

High temperature valve - DN10-50, PN40

Type 55100 - Reduced bore

Technical drawing		Material description	
	3	Female	Steel - S355J2+N / 1.0570 / EN 10025-2
	5	Valve body	Steel - P235GH / 1.0345 / EN 10217-2
	6	Ball	Stainless steel - AISI304L / 1.4306 / EN 10217-7
	7	Seat ring	PTFE 20% Carbon
	8	Back-up ring	Steel - DC01 / 1.0330 / EN 10130
	9	Disc spring	Steel - C75S / 1.1248 / EN 10132-4
	11	Stem guide	Steel - S355J2+N / 1.0570 / EN 10025-2
	12	Stem	Stainless steel - ASTM420 / 1.4021 / EN 10088-3
	13	Stem washer	Stainless steel - AISI304 / 1.4301 / EN 10088-3
	14	Friction washer	PTFE 20% Carbon
	23	ISO-flange	Steel - S235JRG2 / 1.0038 / EN 10025-2
	44	Threaded bush	Stainless steel - AISI303 / 1.4305 / EN 10088-3
	45	Brass ring	Brass B10
	46	Stem gasket	Graphite

High temperature valve - DN10-50, PN40

Type 55102 - Reduced bore

Welding × Welding

Fully welded steel ball valve.

Materials

See next page.

Applications

Isolating valve for steam systems. In case of demand for valves for systems with pressure and temperature outside defined range - please contact BROEN.

Media

Water and steam. Other media on request. If in doubt, please contact BROEN Ballomax® Sales Department.

Surface treatment

Eco-friendly protection finish against corrosion.

Operation

The standard handle is 180 degrees adjustable.

Approvals and certificates

BROEN is certified according to ISO 9001 and environmentally certified according to ISO 14001. BROEN Ballomax® is approved according to the requirements of Pressure Equipment Directive (PED). All ball valves as from DN40 are CE-marked. The 3.1 certificate is available upon request.

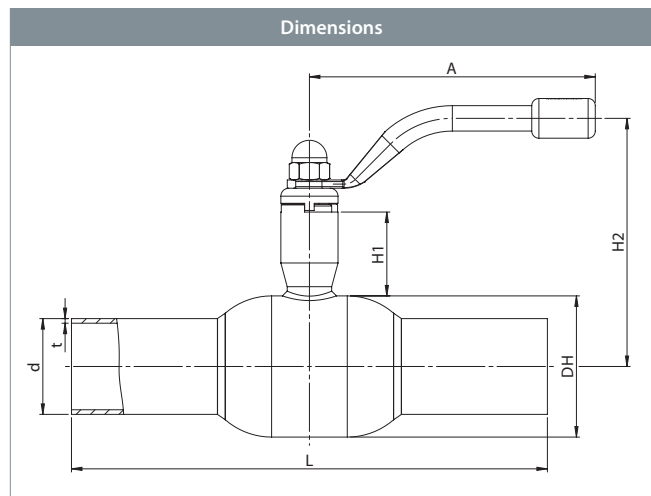

DN	BROEN No.	Bore	Kvs	net Weight kg	All dimensions in mm						
					DH	L	d	t	H1	H2	A
10	5510240010 010	10	7	0.8	38.0	210	17.2	1.8	42	104	140
15	5510240015 010	10	8	0.8	38.0	210	21.3	2.0	42	104	140
20	5510240020 010	15	15	0.8	42.4	230	26.9	2.3	44	107	140
25	5510240025 010	20	27	1.0	51.0	230	33.7	2.6	44	112	140
32	5510240032 010	25	40	1.4	57.0	260	42.4	2.6	45	116	140
40	5510240040 010	32	69	2.2	76.1	260	48.3	2.6	68	150	180
50	5510240050 010	40	110	2.9	88.9	300	60.3	2.9	68	156	180

High temperature valve - DN10-50, PN40

Type 55102 - Reduced bore



Technical drawing		Material description	
	1	Welding	Steel - P235GH / 1.0345 / EN 10217-2
	5	Valve body	Steel - P235GH / 1.0345 / EN 10217-2
	6	Ball	Stainless steel - AISI304L / 1.4306 / EN 10217-7
	7	Seat ring	PTFE 20% Carbon
	8	Back-up ring	Steel - DC01 / 1.0330 / EN 10130
	9	Disc spring	Steel - C75S / 1.1248 / EN 10132-4
	10	Neck ring	Steel - S355J2+N / 1.0570 / EN 10025-2
	11	Stem guide	Steel - S355J2+N / 1.0570 / EN 10025-2
	12	Stem	Stainless steel - ASTM420 / 1.4021 / EN 10088-3
	13	Stem washer	Stainless steel - AISI304 / 1.4301 / EN 10088-3
	14	Friction washer	PTFE 20% Carbon
	20	Handle	Steel
	21	Cap nut	Steel - galvanized
	43	Endplate	Steel - S235JRG2 / 1.0038 / EN 10025-2
44	Threaded bush	Stainless steel - AISI303 / 1.4305 / EN 10088-3	
45	Brass ring	Brass B10	
46	Stem gasket	Graphite	

High temperature valve - DN10-50, PN40

Type 55102 - Reduced bore

Welding × Welding with ISO-flange

Fully welded steel ball valve.

Materials

See next page.

Applications

Isolating valve for steam systems. In case of demand for valves for systems with pressure and temperature outside defined range - please contact BROEN.

Media

Water and steam. Other media on request. If in doubt, please contact BROEN Ballomax® Sales Department.

Surface treatment

Eco-friendly protection finish against corrosion.

Operation

The standard handle is 180 degrees adjustable.

Approvals and certificates

BROEN is certified according to ISO 9001 and environmentally certified according to ISO 14001. BROEN Ballomax® is approved according to the requirements of Pressure Equipment Directive (PED). All ball valves as from DN40 are CE-marked. The 3.1 certificate is available upon request.

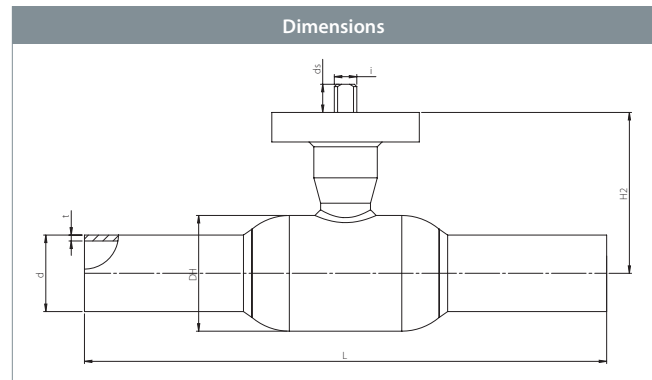

DN	BROEN No.	Bore	Kvs	net Weight kg	All dimensions in mm							
					d	DH	L	t	H2	ds	i	ISO
10	5510240010 300	10	7	0.9	17.2	38.0	210	1.8	63	10	12.5	F5
15	5510240015 300	10	8	0.9	21.3	38.0	210	2.0	63	10	12.5	F5
20	5510240020 300	15	15	0.9	26.9	42.4	230	2.3	67	10	12.5	F5
25	5510240025 300	20	27	1.1	33.7	51.0	230	2.6	71	10	12.5	F5
32	5510240032 300	25	40	1.5	42.4	57.0	260	2.6	75	10	12.5	F5
40	5510240040 300	32	69	2.3	48.3	76.1	260	2.6	106	14	18.0	F7
50	5510240050 300	40	110	3.0	60.3	88.9	300	2.9	112	14	18.0	F7

High temperature valve - DN10-50, PN40

Type 55102 - Reduced bore



Technical drawing		Material description	
	1	Welding	Steel - P235GH / 1.0345 / EN 10217-2
	5	Valve body	Steel - P235GH / 1.0345 / EN 10217-2
	6	Ball	Stainless steel - AISI304L / 1.4306 / EN 10217-7
	7	Seat ring	PTFE 20% Carbon
	8	Back-up ring	Steel - DC01 / 1.0330 / EN 10130
	9	Disc spring	Steel - C75S / 1.1248 / EN 10132-4
	11	Stem guide	Steel - S355J2+N / 1.0570 / EN 10025-2
	12	Stem	Stainless steel - ASTM420 / 1.4021 / EN 10088-3
	13	Stem washer	Stainless steel - AISI304 / 1.4301 / EN 10088-3
	14	Friction washer	PTFE 20% Carbon
	23	ISO-flange	Steel - S235JRG2 / 1.0038 / EN 10025-2
	44	Threaded bush	Stainless steel - AISI303 / 1.4305 / EN 10088-3
	45	Brass ring	Brass B10
	46	Stem gasket	Graphite

High temperature valve - DN65-200, PN25

Type 55102 - Reduced bore

Welding × Welding

Fully welded steel ball valve.

Materials

See next page.

Applications

Isolating valve for steam systems. In case of demand for valves for systems with pressure and temperature outside defined range - please contact BROEN.

Media

Water and steam. Other media on request. If in doubt, please contact BROEN Ballomax® Sales Department.

Surface treatment

Eco-friendly protection finish against corrosion.

Operation

The standard handle is 180 degrees adjustable.

Approvals and certificates

BROEN is certified according to ISO 9001 and environmentally certified according to ISO 14001. BROEN Ballomax® is approved according to the requirements of Pressure Equipment Directive (PED). All ball valves as from DN40 are CE-marked. The 3.1 certificate is available upon request.

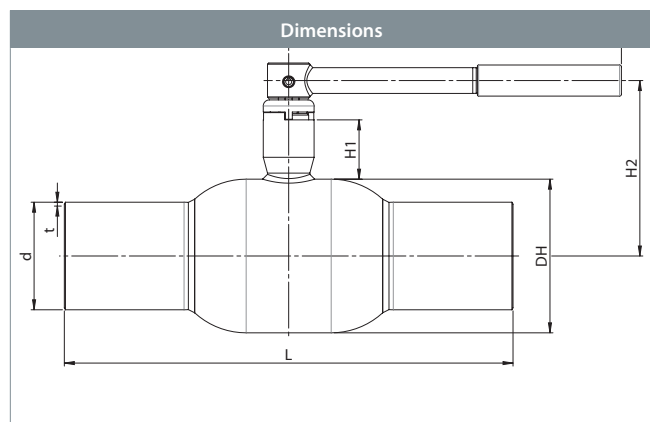

DN	BROEN No.	Bore	Kvs	net Weight kg	All dimensions in mm						
					DH	L	d	t	H1	H2	A
65	5510225065 010	50	180	4.5	108.0	360	76.1	2.9	65	135	275
80	5510225080 010	65	288	5.9	127.0	370	88.9	3.2	66	145	275
100	5510225100 010	80	417	9.4	152.4	390	114.3	3.6	81	178	365
125	5510225125 010	100	699	13.0	177.8	390	139.7	3.6	104	217	365
150	5510225150 010	125	1046	19.9	219.1	390	168.3	4.0	103	240	650
200	5510225200 010	150	1500	35.2	267.0	390	219.1	4.5	153	318	900

High temperature valve - DN65-200, PN25

Type 55102 - Reduced bore

Technical drawing		Material description	
	1	Welding	Steel - P235GH / 1.0345 / EN 10217-2
	5	Valve body	Steel - P235GH / 1.0345 / EN 10217-2
	6	Ball	Stainless steel - AISI304L / 1.4306 / EN 10217-7
	7	Seat ring	PTFE 20% Carbon
	8	Back-up ring	Steel - DC01 / 1.0330 / EN 10130
	9	Disc spring	Steel - C75S / 1.1248 / EN 10132-4
	10	Neck ring	Steel - S355J2+N / 1.0570 / EN 10025-2
	11	Stem guide	Steel - S355J2+N / 1.0570 / EN 10025-2
	12	Stem	Stainless steel - ASTM420 / 1.4021 / EN 10088-3
	13	Stem washer	Stainless steel - AISI304 / 1.4301 / EN 10088-3
	14	Friction washer	PTFE 20% Carbon
	20	Handle	Steel
	39	Spring pin	Steel
	43	Endplate	Steel - S235JRG2 / 1.0038 / EN 10025-2
44	Threaded bush	Stainless steel - AISI303 / 1.4305 / EN 10088-3	
45	Brass ring	Brass B10	
46	Stem gasket	Graphite	

High temperature valve - DN65-200, PN25

Type 55102 - Reduced bore

Welding × Welding with ISO-flange

Fully welded steel ball valve.

Materials

See next page.

Applications

Isolating valve for steam systems. In case of demand for valves for systems with pressure and temperature outside defined range - please contact BROEN.

Media

Water and steam. Other media on request. If in doubt, please contact BROEN Ballomax® Sales Department.

Surface treatment

Eco-friendly protection finish against corrosion.

Operation

The standard handle is 180 degrees adjustable.

Approvals and certificates

BROEN is certified according to ISO 9001 and environmentally certified according to ISO 14001. BROEN Ballomax® is approved according to the requirements of Pressure Equipment Directive (PED). All ball valves as from DN40 are CE-marked. The 3.1 certificate is available upon request.

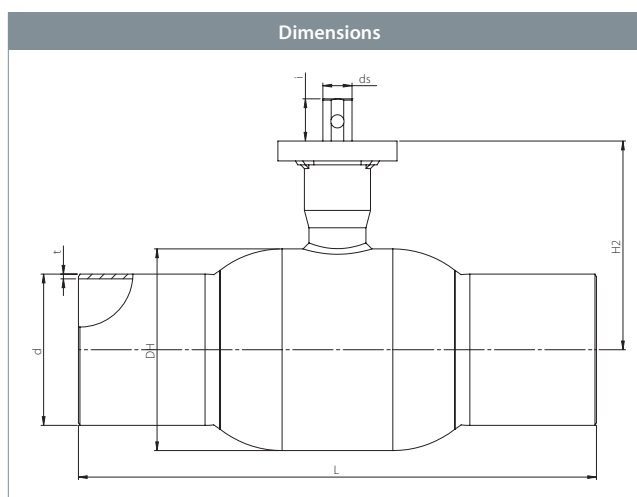

DN	BROEN No.	Bore	Kvs	net Weight kg	All dimensions in mm							
					d	DH	L	t	H2	ds	i	ISO
65	5510225065 300	50	180	4.5	76.1	108.0	360	2.9	149	17	29.5	F7
80	5510225080 300	65	288	5.9	88.9	127.0	370	3.2	159	17	29.5	F7
100	5510225100 300	80	417	8.9	114.3	152.4	390	3.6	190	22	31.9	F7
125	5510225125 300	100	699	13.8	139.7	177.8	390	3.6	229	24	32.0	F10
150	5510225150 300	125	1046	18.7	168.3	219.1	390	4.0	269	30	53.3	F10
200	5510225200 300	150	1500	31.4	219.1	267.0	390	4.5	349	30	62.8	F14

High temperature valve - DN65-200, PN25

Type 55102 - Reduced bore



Technical drawing		Material description	
	1	Welding	Steel - P235GH / 1.0345 / EN 10217-2
	5	Valve body	Steel - P235GH / 1.0345 / EN 10217-2
	6	Ball	Stainless steel - AISI304L / 1.4306 / EN 10217-7
	7	Seat ring	PTFE 20% Carbon
	8	Back-up ring	Steel - DC01 / 1.0330 / EN 10130
	9	Disc spring	Steel - C75S / 1.1248 / EN 10132-4
	11	Stem guide	Steel - S355J2+N / 1.0570 / EN 10025-2
	12	Stem	Stainless steel - ASTM420 / 1.4021 / EN 10088-3
	13	Stem washer	Stainless steel - AISI304 / 1.4301 / EN 10088-3
	14	Friction washer	PTFE 20% Carbon
	23	ISO-flange	Steel - S235JRG2 / 1.0038 / EN 10025-2
	44	Threaded bush	Stainless steel - AISI303 / 1.4305 / EN 10088-3
	45	Brass ring	Brass B10
	46	Stem gasket	Graphite

High temperature valve - DN125-200, PN25

Type 55102 - Reduced bore

Welding × Welding with ISO-flange and BROEN-Gear

Fully welded steel ball valve.

Materials

See next page.

Applications

Isolating valve for steam systems. In case of demand for valves for systems with pressure and temperature outside defined range - please contact BROEN.

Media

Water and steam. Other media on request. If in doubt, please contact BROEN Ballomax® Sales Department.

Surface treatment

Eco-friendly protection finish against corrosion.

Approvals and certificates

BROEN is certified according to ISO 9001 and environmentally certified according to ISO 14001. BROEN Ballomax® is approved according to the requirements of Pressure Equipment Directive (PED). All ball valves as from DN40 are CE-marked. The 3.1 certificate is available upon request.

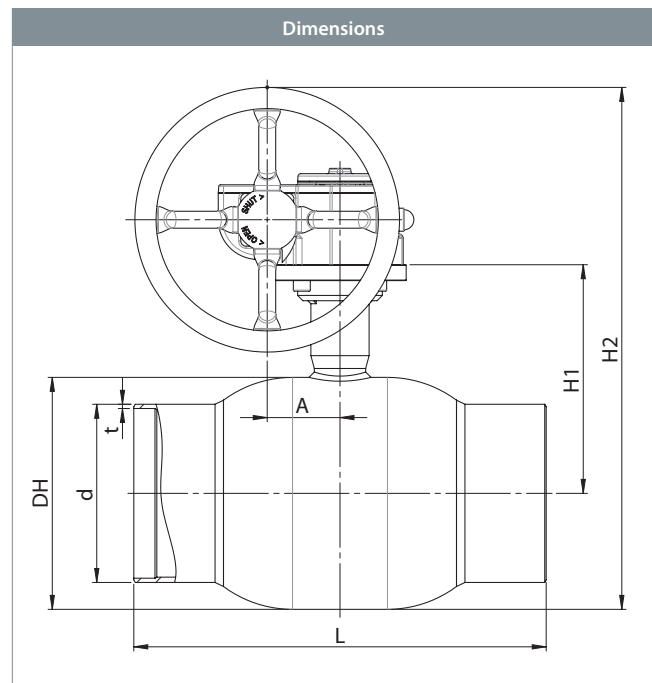

DN	BROEN No.	Bore	Kvs	net Weight kg	All dimensions in mm							
					DH	L	d	t	H1	H2	dp	A
125	5510225125 480	100	699	18.2	177.8	390	139.7	3.6	197	224	200	55
150	5510225150 480	125	1046	26.5	219.1	390	168.3	4.0	216	250	300	69
200	5510225200 480	150	1500	39.2	267.0	390	219.1	4.5	286	320	300	69

High temperature valve - DN125-200, PN25

Type 55102 - Reduced bore

Technical drawing		Material description	
	1	Welding	Steel - P235GH / 1.0345 / EN 10217-2
	5	Valve body	Steel - P235GH / 1.0345 / EN 10217-2
	6	Ball	Stainless steel - AISI304L / 1.4306 / EN 10217-7
	7	Seat ring	PTFE 20% Carbon
	8	Back-up ring	Steel - DC01 / 1.0330 / EN 10130
	9	Disc spring	Steel - C75S / 1.1248 / EN 10132-4
	10	Neck ring	Steel - S355J2+N / 1.0570 / EN 10025-2
	11	Stem guide	Steel - S355J2+N / 1.0570 / EN 10025-2
	12	Stem	Stainless steel - ASTM420 / 1.4021 / EN 10088-3
	23	ISO-flange	Steel - S235JRG2 / 1.0038 / EN 10025-2
	25	Friction gasket	PTFE 20% Carbon
	44	Threaded bush	Stainless steel - AISI303 / 1.4305 / EN 10088-3
	45	Brass ring	Brass B10
	46	Stem gasket	Graphite

High temperature valve - DN15-50, PN40

Type 55103 - Reduced bore

Flange × Flange

Fully welded steel ball valve.

Materials

See next page.

Applications

Isolating valve for steam systems. In case of demand for valves for systems with pressure and temperature outside defined range - please contact BROEN.

Media

Water and steam. Other media on request. If in doubt, please contact BROEN Ballomax® Sales Department.

Surface treatment

Eco-friendly protection finish against corrosion.

Operation

The standard handle is 180 degrees adjustable.

Approvals and certificates

BROEN is certified according to ISO 9001 and environmentally certified according to ISO 14001. BROEN Ballomax® is approved according to the requirements of Pressure Equipment Directive (PED). All ball valves as from DN40 are CE-marked. The 3.1 certificate is available upon request.

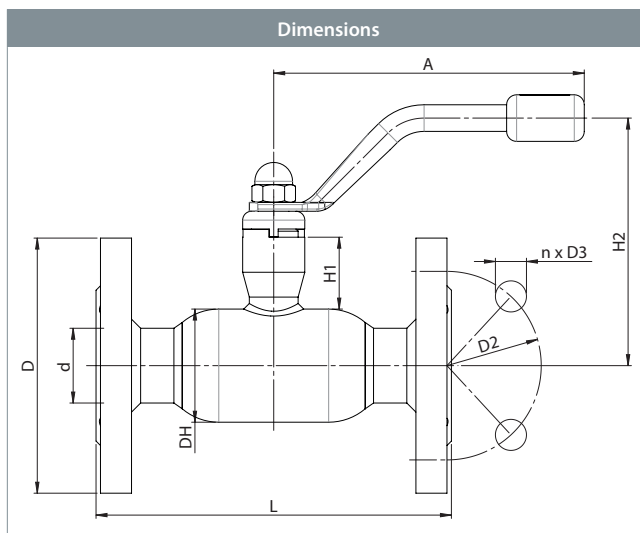

DN	BROEN No.	Bore	Kvs	net Weight kg	All dimensions in mm								
					L	DH	H1	H2	D1	D2	A	n	D3
15	5510340015 010	10	8	1.8	130	38.0	43	104	95	65	140	4	14
20	5510340020 010	15	15	2.4	150	42.4	44	107	105	75	140	4	14
25	5510340025 010	20	27	2.9	160	51.0	44	112	115	85	140	4	14
32	5510340032 010	25	40	4.5	180	57.0	45	116	140	100	140	4	18
40	5510340040 010	32	69	5.8	200	76.1	68	150	150	110	180	4	18
50	5510340050 010	40	110	7.6	230	88.9	68	156	165	125	180	4	18

High temperature valve - DN15-50, PN40



Type 55103 - Reduced bore

Technical drawing		Material description	
	1	Welding	Steel - P235GH / 1.0345 / EN 10217-2
	2	Flange	Steel - S235JRG2 / 1.0038 / EN 10025-2
	5	Valve body	Steel - P235GH / 1.0345 / EN 10217-2
	6	Ball	Stainless steel - AISI304L / 1.4306 / EN 10217-7
	7	Seat ring	PTFE 20% Carbon
	8	Back-up ring	Steel - DC01 / 1.0330 / EN 10130
	9	Disc spring	Steel - C75S / 1.1248 / EN 10132-4
	10	Neck ring	Steel - S355J2+N / 1.0570 / EN 10025-2
	11	Stem guide	Steel - S355J2+N / 1.0570 / EN 10025-2
	12	Stem	Stainless steel - ASTM420 / 1.4021 / EN 10088-3
	13	Stem washer	Stainless steel - AISI304 / 1.4301 / EN 10088-3
	14	Friction washer	PTFE 20% Carbon
	20	Handle	Steel
	21	Cap nut	Steel - galvanized
	43	Endplate	Steel - S235JRG2 / 1.0038 / EN 10025-2
	44	Threaded bush	Stainless steel - AISI303 / 1.4305 / EN 10088-3
45	Brass ring	Brass B10	
46	Stem gasket	Graphite	

High temperature valve - DN15-50, PN40

Type 55103 - Reduced bore

Flange × Flange with ISO-flange

Fully welded steel ball valve.

Materials

See next page.

Applications

Isolating valve for steam systems. In case of demand for valves for systems with pressure and temperature outside defined range - please contact BROEN.

Media

Water and steam. Other media on request. If in doubt, please contact BROEN Ballomax® Sales Department.

Surface treatment

Eco-friendly protection finish against corrosion.

Operation

The standard handle is 180 degrees adjustable.

Approvals and certificates

BROEN is certified according to ISO 9001 and environmentally certified according to ISO 14001. BROEN Ballomax® is approved according to the requirements of Pressure Equipment Directive (PED). All ball valves as from DN40 are CE-marked. The 3.1 certificate is available upon request.

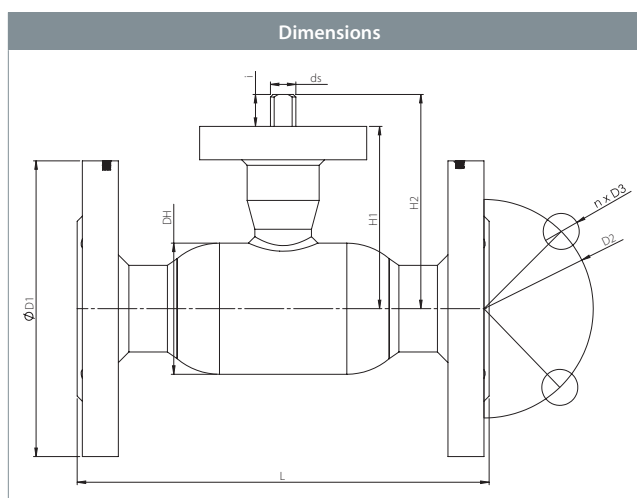
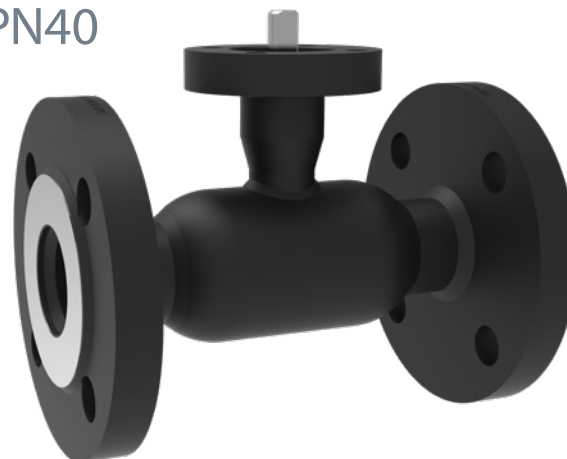

DN	BROEN No.	Bore	Kvs	net Weight kg	All dimensions in mm										
					L	DH	H1	H2	D1	D2	n	D3	ds	i	ISO
15	5510340015 300	10	8	1,9	130	38,0	63	75,5	95	65	4	14	10	12,5	F5
20	5510340020 300	15	15	2,5	150	42,4	67	80,0	105	75	4	14	10	12,5	F5
25	5510340025 300	20	27	3,0	160	51,0	71	83,0	115	85	4	14	10	12,5	F5
32	5510340032 300	25	40	4,6	180	57,0	75	87,5	140	100	4	18	10	12,5	F5
40	5510340040 300	32	69	5,9	200	76,1	106	124,0	150	110	4	18	14	18,0	F7
50	5510340050 300	40	110	7,8	230	88,9	112	130,0	165	125	4	18	14	18,0	F7

High temperature valve - DN15-50, PN40

Type 55103 - Reduced bore

Technical drawing		Material description	
	2	Flange	Steel - S235JRG2 / 1.0038 / EN 10025-2
	5	Valve body	Steel - P235GH / 1.0345 / EN 10217-2
	6	Ball	Stainless steel - AISI304L / 1.4306 / EN 10217-7
	7	Seat ring	PTFE 20% Carbon
	8	Back-up ring	Steel - DC01 / 1.0330 / EN 10130
	9	Disc spring	Steel - C75S / 1.1248 / EN 10132-4
	10	Neck ring	Steel - S355J2+N / 1.0570 / EN 10025-2
	11	Stem guide	Steel - S355J2+N / 1.0570 / EN 10025-2
	12	Stem	Stainless steel - ASTM420 / 1.4021 / EN 10088-3
	14	Friction washer	PTFE 20% Carbon
	44	Threaded bush	Stainless steel - AISI303 / 1.4305 / EN 10088-3
	45	Brass ring	Brass B10
	46	Stem gasket	Graphite

High temperature valve - DN65-200, PN25

Type 55103 - Reduced bore

Flange × Flange

Fully welded steel ball valve.

Materials

See next page.

Applications

Isolating valve for steam systems. In case of demand for valves for systems with pressure and temperature outside defined range - please contact BROEN.

Media

Water and steam. Other media on request. If in doubt, please contact BROEN Ballomax® Sales Department.

Surface treatment

Eco-friendly protection finish against corrosion.

Operation

The standard handle is 180 degrees adjustable.

Approvals and certificates

BROEN is certified according to ISO 9001 and environmentally certified according to ISO 14001. BROEN Ballomax® is approved according to the requirements of Pressure Equipment Directive (PED). All ball valves as from DN40 are CE-marked. The 3.1 certificate is available upon request.

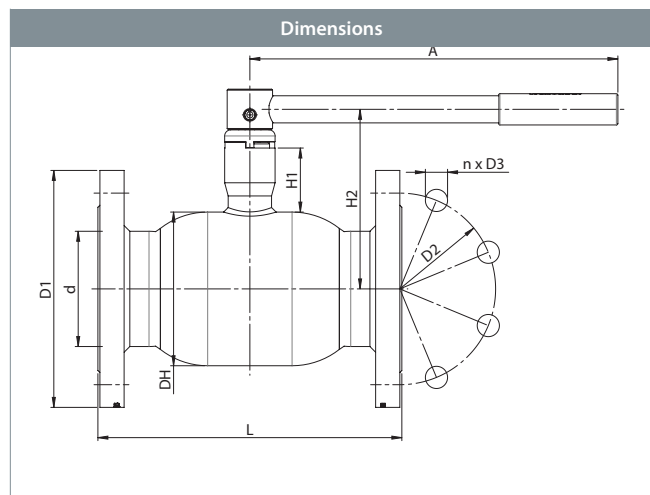

DN	BROEN No.	Bore	Kvs	net Weight kg	All dimensions in mm								
					L	DH	H1	H2	D1	D2	A	n	D3
65	5510325065 010	50	180	10.7	290	108.0	65	135	185	145	275	8	18
80	5510325080 010	65	288	13.4	280	127.0	65	145	200	160	275	8	18
100	5510325100 010	80	417	20.0	300	152.0	81	178	235	190	365	8	22
125	5510325125 010	100	699	27.9	325	177.8	103	217	270	220	365	8	26
150	5510325150 010	125	1046	38.7	350	219.1	103	240	300	250	650	8	26
200	5510325200 010	150	1500	63.0	400	267.0	153	318	360	310	900	12	26

High temperature valve - DN65-200, PN25

Type 55103 - Reduced bore

Technical drawing		Material description	
	1	Welding	Steel - P235GH / 1.0345 / EN 10217-2
	2	Flange	Steel - S235JRG2 / 1.0038 / EN 10025-2
	5	Valve body	Steel - P235GH / 1.0345 / EN 10217-2
	6	Ball	Stainless steel - AISI304L / 1.4306 / EN 10217-7
	7	Seat ring	PTFE 20% Carbon
	8	Back-up ring	Steel - DC01 / 1.0330 / EN 10130
	9	Disc spring	Steel - C75S / 1.1248 / EN 10132-4
	10	Neck ring	Steel - S355J2+N / 1.0570 / EN 10025-2
	11	Stem guide	Steel - S355J2+N / 1.0570 / EN 10025-2
	12	Stem	Stainless steel - ASTM420 / 1.4021 / EN 10088-3
	13	Stem washer	Stainless steel - AISI304 / 1.4301 / EN 10088-3
	14	Friction washer	PTFE 20% Carbon
	20	Handle	Steel
	39	Spring pin	Steel
	43	Endplate	Steel - S235JRG2 / 1.0038 / EN 10025-2
	44	Threaded bush	Stainless steel - AISI303 / 1.4305 / EN 10088-3
45	Brass ring	Brass B10	
46	Stem gasket	Graphite	

High temperature valve - DN65-200, PN25

Type 55103 - Reduced bore

Flange × Flange with ISO-flange

Fully welded steel ball valve.

Materials

See next page.

Applications

Isolating valve for steam systems. In case of demand for valves for systems with pressure and temperature outside defined range - please contact BROEN.

Media

Water and steam. Other media on request. If in doubt, please contact BROEN Ballomax® Sales Department.

Surface treatment

Eco-friendly protection finish against corrosion.

Operation

The following operating devices are available on request:

- BROEN-Gear.
- Electric actuator.

Approvals and certificates

BROEN is certified according to ISO 9001 and environmentally certified according to ISO 14001. BROEN Ballomax® is approved according to the requirements of Pressure Equipment Directive (PED). All ball valves as from DN40 are CE-marked. The 3.1 certificate is available upon request.

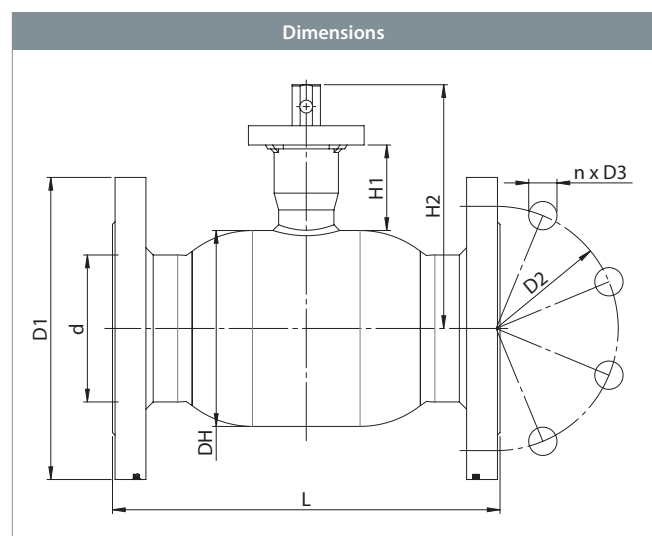

DN	BROEN No.	Bore	Kvs	net Weight kg	All dimensions in mm										
					L	DH	H1	H2	D1	D2	n	D3	ds	i	ISO
65	5510325065 300	50	180	10,7	290	108,0	120	149	185	145	8	18	17	29,5	F7
80	5510325080 300	65	288	13,4	280	127,0	130	159	200	160	8	18	17	29,5	F7
100	5510325100 300	80	417	19,5	300	152,0	158	190	235	160	8	22	22	31,9	F7
125	5510325125 300	100	699	28,4	325	177,8	197	229	270	220	8	26	24	32,0	F10
150	5510325150 300	125	1046	37,5	350	219,1	216	269	300	250	8	26	30	53,3	F10
200	5510325200 300	150	1500	59,2	400	267,0	286	349	360	310	12	26	36	62,8	F14

High temperature valve - DN65-200, PN25

Type 55103 - Reduced bore

Technical drawing		Material description	
	1	Welding	Steel - P235GH / 1.0345 / EN 10217-2
	2	Flange	Steel - S235JRG2 / 1.0038 / EN 10025-2
	5	Valve body	Steel - P235GH / 1.0345 / EN 10217-2
	6	Ball	Stainless steel - AISI304L / 1.4306 / EN 10217-7
	7	Seat ring	PTFE 20% Carbon
	8	Back-up ring	Steel - DC01 / 1.0330 / EN 10130
	9	Disc spring	Steel - C75S / 1.1248 / EN 10132-4
	10	Neck ring	Steel - S355J2+N / 1.0570 / EN 10025-2
	11	Stem guide	Steel - S355J2+N / 1.0570 / EN 10025-2
	12	Stem	Stainless steel - ASTM420 / 1.4021 / EN 10088-3
	13	Stem washer	Stainless steel - AISI304 / 1.4301 / EN 10088-3
	14	Friction washer	PTFE 20% Carbon
	23	ISO-flange	Steel - S235JRG2 / 1.0038 / EN 10025-2
	44	Threaded bush	Stainless steel - AISI303 / 1.4305 / EN 10088-3
45	Brass ring	Brass B10	
46	Stem gasket	Graphite	

Accessories	BROEN No.	Dimension	Description
	600583	DN100	BROEN-Gear.
	600584	DN125	
	600585	DN150	
	600586	DN200	

High temperature valve - DN125-200, PN25

Type 55103 - Reduced bore

Welding × Welding with ISO-flange and BROEN-Gear

Fully welded steel ball valve.

Materials

See next page.

Applications

Isolating valve for steam systems. In case of demand for valves for systems with pressure and temperature outside defined range - please contact BROEN.

Media

Water and steam. Other media on request. If in doubt, please contact BROEN Ballomax® Sales Department.

Surface treatment

Eco-friendly protection finish against corrosion.

Approvals and certificates

BROEN is certified according to ISO 9001 and environmentally certified according to ISO 14001. BROEN Ballomax® is approved according to the requirements of Pressure Equipment Directive (PED). All ball valves as from DN40 are CE-marked. The 3.1 certificate is available upon request.

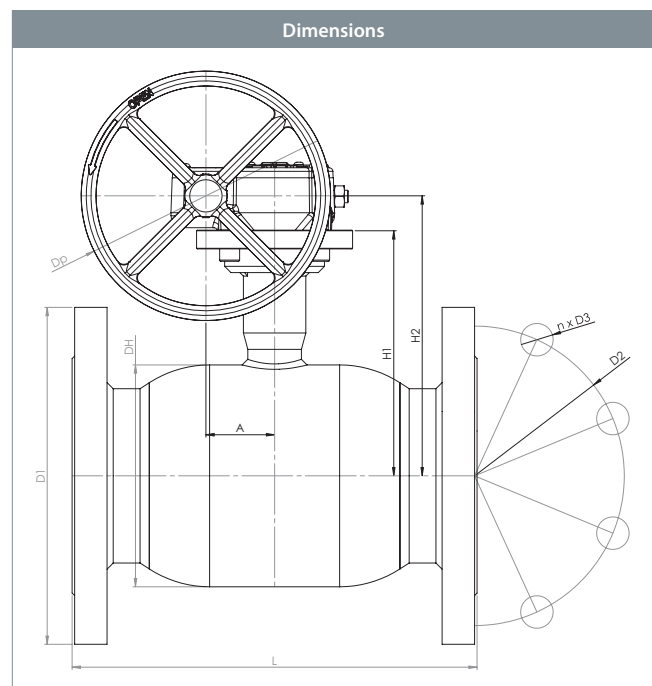

DN	BROEN No.	Bore	Kvs	net Weight kg	All dimensions in mm									
					L	DH	H1	H2	D1	D2	n	D3	p	A
125	5510325125 480	100	699	32.8	325	177.8	197	224	270	220	8	26	200	55
150	5510325150 480	125	1046	45.3	350	219.1	216	250	300	250	8	26	300	69
200	5510325200 480	150	1500	67.0	400	267.0	286	320	360	310	12	26	300	69

High temperature valve - DN125-200, PN25

Type 55103 - Reduced bore

Technical drawing		Material description	
	3	Female	Steel - S355J2+N / 1.0570 / EN 10025-2
	5	Valve body	Steel - P235GH / 1.0345 / EN 10217-2
	6	Ball	Stainless steel - AISI304L / 1.4306 / EN 10217-7
	7	Seat ring	PTFE 20% Carbon
	8	Back-up ring	Steel - DC01 / 1.0330 / EN 10130
	9	Disc spring	Steel - C75S / 1.1248 / EN 10132-4
	11	Stem guide	Steel - S355J2+N / 1.0570 / EN 10025-2
	12	Stem	Stainless steel - ASTM420 / 1.4021 / EN 10088-3
	13	Stem washer	Stainless steel - AISI304 / 1.4301 / EN 10088-3
	14	Friction washer	PTFE 20% Carbon
	23	ISO-flange	Steel - S235JRG2 / 1.0038 / EN 10025-2
	44	Threaded bush	Stainless steel - AISI303 / 1.4305 / EN 10088-3
	45	Brass ring	Brass B10
	46	Stem gasket	Graphite
47	Gear	-	

High temperature valve - DN65-200, PN16

Type 55103 - Reduced bore

Flange × Flange

Fully welded steel ball valve.

Materials

See next page.

Applications

Isolating valve for steam systems. In case of demand for valves for systems with pressure and temperature outside defined range - please contact BROEN.

Media

Water and steam. Other media on request. If in doubt, please contact BROEN Ballomax® Sales Department.

Surface treatment

Eco-friendly protection finish against corrosion.

Operation

The standard handle is 180 degrees adjustable.

Approvals and certificates

BROEN is certified according to ISO 9001 and environmentally certified according to ISO 14001. BROEN Ballomax® is approved according to the requirements of Pressure Equipment Directive (PED). All ball valves as from DN40 are CE-marked. The 3.1 certificate is available upon request.

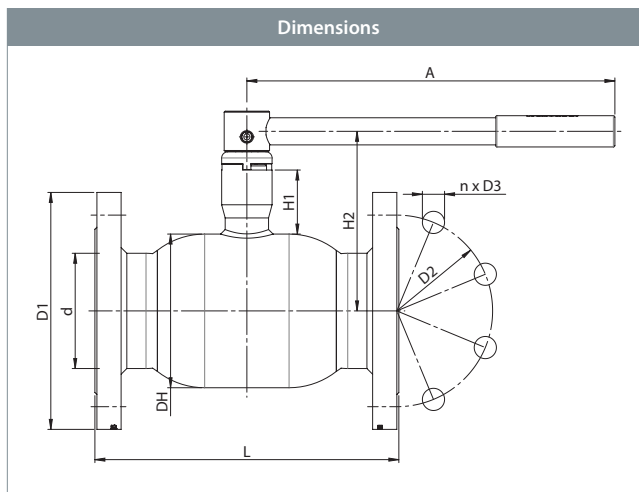

DN	BROEN No.	Bore	Kvs	net Weight kg	All dimensions in mm								
					L	DH	H1	H2	D1	D2	A	n	D3
65	5510316065 010	50	180	11.0	290	108.0	65	135	185	145	275	4	18
80	5510316080 010	65	288	12.0	280	127.0	65	145	200	160	275	8	18
100	5510316100 010	80	417	16.7	300	152.0	81	178	220	180	365	8	18
125	5510316125 010	100	699	22.4	325	177.8	103	217	250	210	365	8	18
150	5510316150 010	125	1046	32.4	350	219.1	103	240	285	240	650	8	22
200	5510316200 010	150	1500	54.9	400	267.0	153	318	340	295	900	8	22

High temperature valve - DN65-200, PN16

Type 55103 - Reduced bore

Technical drawing		Material description	
	1	Welding	Steel - P235GH / 1.0345 / EN 10217-2
	2	Flange	Steel - S235JRG2 / 1.0038 / EN 10025-2
	5	Valve body	Steel - P235GH / 1.0345 / EN 10217-2
	6	Ball	Stainless steel - AISI304L / 1.4306 / EN 10217-7
	7	Seat ring	PTFE 20% Carbon
	8	Back-up ring	Steel - DC01 / 1.0330 / EN 10130
	9	Disc spring	Steel - C75S / 1.1248 / EN 10132-4
	10	Neck ring	Steel - S355J2+N / 1.0570 / EN 10025-2
	11	Stem guide	Steel - S355J2+N / 1.0570 / EN 10025-2
	12	Stem	Stainless steel - ASTM420 / 1.4021 / EN 10088-3
	13	Stem washer	Stainless steel - AISI304 / 1.4301 / EN 10088-3
	14	Friction washer	PTFE 20% Carbon
	20	Handle	Steel
	39	Spring pin	Steel
	43	Endplate	Steel - S235JRG2 / 1.0038 / EN 10025-2
	44	Threaded bush	Stainless steel - AISI303 / 1.4305 / EN 10088-3
45	Brass ring	Brass B10	
46	Stem gasket	Graphite	

High temperature valve - DN65-200, PN16

Type 55103 - Reduced bore

Flange × Flange with ISO-flange

Fully welded steel ball valve.

Materials

See next page.

Applications

Isolating valve for steam systems. In case of demand for valves for systems with pressure and temperature outside defined range - please contact BROEN.

Media

Water and steam. Other media on request. If in doubt, please contact BROEN Ballomax® Sales Department.

Surface treatment

Eco-friendly protection finish against corrosion.

Operation

The following operating devices are available on request:

- BROEN-Gear.
- Electric actuator.

Approvals and certificates

BROEN is certified according to ISO 9001 and environmentally certified according to ISO 14001. BROEN Ballomax® is approved according to the requirements of Pressure Equipment Directive (PED). All ball valves as from DN40 are CE-marked. The 3.1 certificate is available upon request.

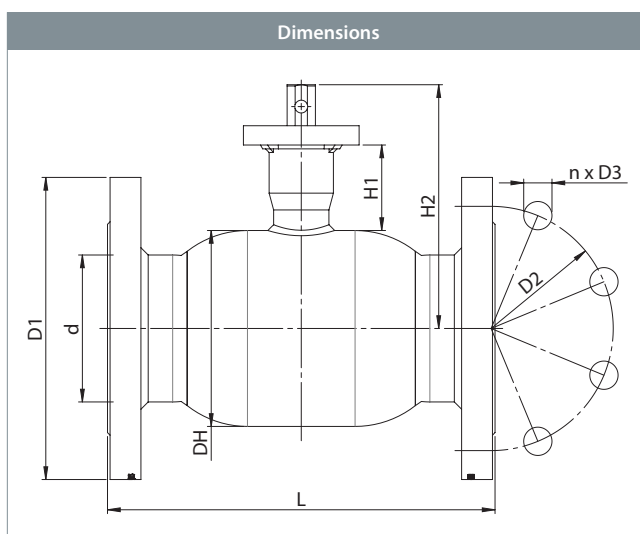

DN	BROEN No.	Bore	Kvs	net Weight kg	All dimensions in mm										
					L	DH	H1	H2	D1	D2	n	D3	ds	i	ISO
65	5510316065 300	50	180	11,0	290	108,0	120	149	185	145	4	18	17	29,5	F7
80	5510316080 300	65	288	12,0	280	127,0	130	159	200	160	8	18	17	29,5	F7
100	5510316100 300	80	417	16,9	300	152,0	158	190	220	180	8	18	22	31,9	F7
125	5510316125 300	100	699	22,8	325	177,8	197	229	250	210	8	18	24	32,0	F10
150	5510316150 300	125	1046	32,6	350	219,1	216	269	285	240	8	22	30	53,3	F10
200	5510316200 300	150	1500	55,1	400	267,0	286	349	340	295	8	22	36	62,8	F14

High temperature valve - DN65-200, PN16

Type 55103 - Reduced bore

Technical drawing		Material description	
	1	Welding	Steel - P235GH / 1.0345 / EN 10217-2
	2	Flange	Steel - S235JRG2 / 1.0038 / EN 10025-2
	5	Valve body	Steel - P235GH / 1.0345 / EN 10217-2
	6	Ball	Stainless steel - AISI304L / 1.4306 / EN 10217-7
	7	Seat ring	PTFE 20% Carbon
	8	Back-up ring	Steel - DC01 / 1.0330 / EN 10130
	9	Disc spring	Steel - C75S / 1.1248 / EN 10132-4
	10	Neck ring	Steel - S355J2+N / 1.0570 / EN 10025-2
	11	Stem guide	Steel - S355J2+N / 1.0570 / EN 10025-2
	12	Stem	Stainless steel - ASTM420 / 1.4021 / EN 10088-3
	13	Stem washer	Stainless steel - AISI304 / 1.4301 / EN 10088-3
	14	Friction washer	PTFE 20% Carbon
	23	ISO-flange	Steel - S235JRG2 / 1.0038 / EN 10025-2
	44	Threaded bush	Stainless steel - AISI303 / 1.4305 / EN 10088-3
45	Brass ring	Brass B10	
46	Stem gasket	Graphite	

Accessories	BROEN No.	Dimension	Description
	600583	DN100	BROEN-Gear.
	600584	DN125	
	600585	DN150	
	600586	DN200	

High temperature valve - DN125-200, PN25

Type 55103 - Reduced bore

Welding × Welding with ISO-flange and BROEN-Gear

Fully welded steel ball valve.

Materials

See next page.

Applications

Isolating valve for steam systems. In case of demand for valves for systems with pressure and temperature outside defined range - please contact BROEN.

Media

Water and steam. Other media on request. If in doubt, please contact BROEN Ballomax® Sales Department.

Surface treatment

Eco-friendly protection finish against corrosion.

Approvals and certificates

BROEN is certified according to ISO 9001 and environmentally certified according to ISO 14001. BROEN Ballomax® is approved according to the requirements of Pressure Equipment Directive (PED). All ball valves as from DN40 are CE-marked. The 3.1 certificate is available upon request.

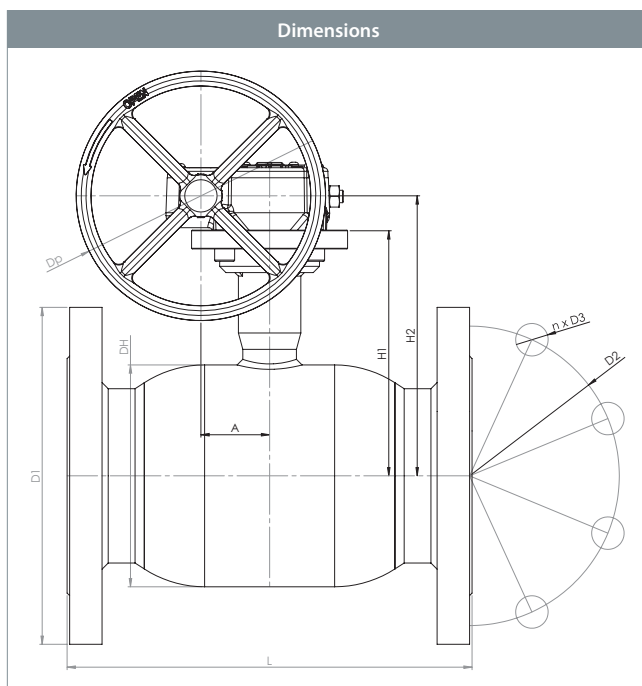

DN	BROEN No.	Bore	Kvs	net Weight kg	All dimensions in mm									
					L	DH	H1	H2	D1	D2	n	D3	p	A
125	5510316125 480	100	699	27.2	325	177.8	197	224	250	210	8	18	200	55
150	5510316150 480	125	1046	39.0	350	219.1	216	250	285	240	8	22	300	69
200	5510316200 480	150	1500	63.8	400	267.0	286	320	340	295	8	22	300	69

High temperature valve - DN125-200, PN25

Type 55103 - Reduced bore

Technical drawing		Material description	
	3	Female	Steel - S355J2+N / 1.0570 / EN 10025-2
	5	Valve body	Steel - P235GH / 1.0345 / EN 10217-2
	6	Ball	Stainless steel - AISI304L / 1.4306 / EN 10217-7
	7	Seat ring	PTFE 20% Carbon
	8	Back-up ring	Steel - DC01 / 1.0330 / EN 10130
	9	Disc spring	Steel - C75S / 1.1248 / EN 10132-4
	11	Stem guide	Steel - S355J2+N / 1.0570 / EN 10025-2
	12	Stem	Stainless steel - ASTM420 / 1.4021 / EN 10088-3
	13	Stem washer	Stainless steel - AISI304 / 1.4301 / EN 10088-3
	14	Friction washer	PTFE 20% Carbon
	23	ISO-flange	Steel - S235JRG2 / 1.0038 / EN 10025-2
	44	Threaded bush	Stainless steel - AISI303 / 1.4305 / EN 10088-3
	45	Brass ring	Brass B10
	46	Stem gasket	Graphite
47	Gear	-	

BROEN-Gear - DN100-200

Type 500... / 300... - Reduced bore

BROEN-Gear

Hand-operated gearbox.

BROEN-Gear is a strong high quality hand-operated gearbox. The hand wheel is ergonomically designed.

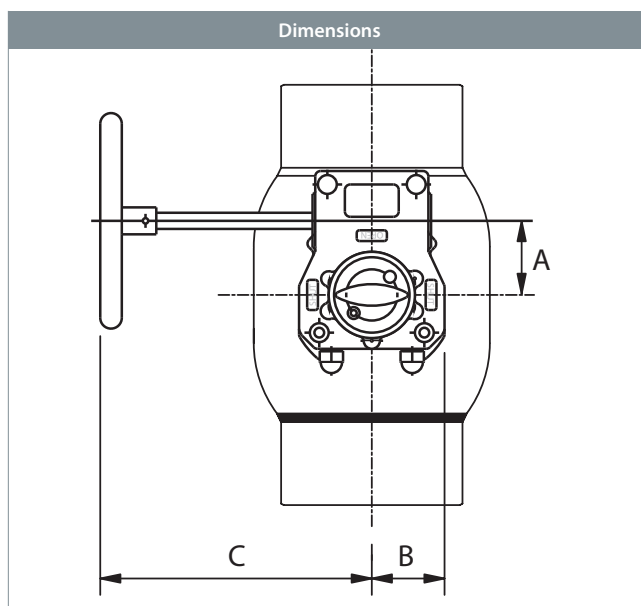

DN	BROEN No.	net Weight kg*	All dimensions in mm				
			A	B	C	Nm	Hand wheel
100	600583	4,4	55,0	53,5	162	650	200
125	600584	2,5	41,3	40,0	145	300	200
150	600585	7,8	68,8	67,5	240	1200	300
200	600586	8,6	68,8	67,5	245	1200	350

* Weight gearbox with hand wheel.

Pressure and temperature graph - DN10-200 - PN40/25/16

Reduced bore

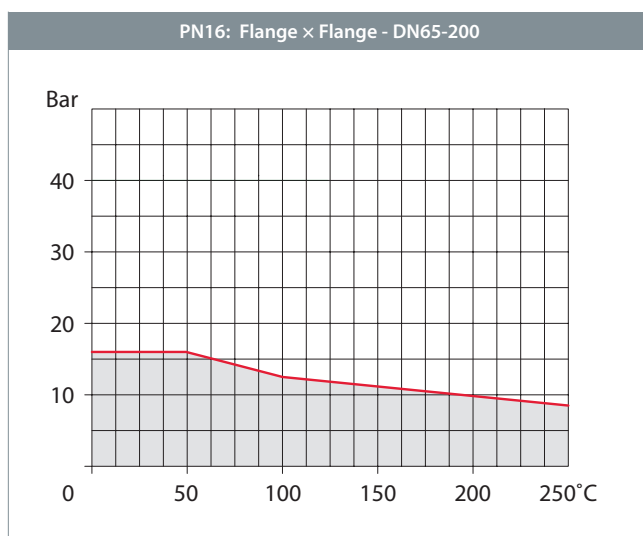
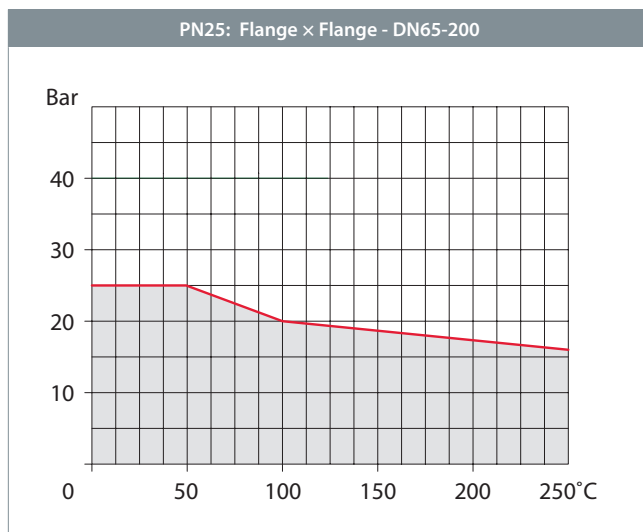
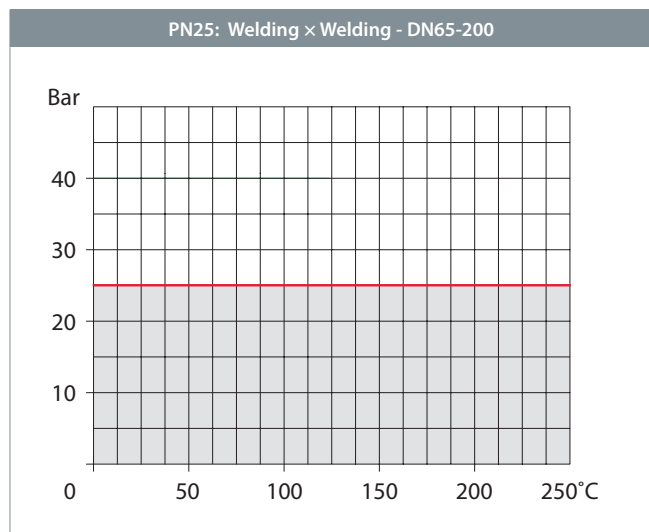
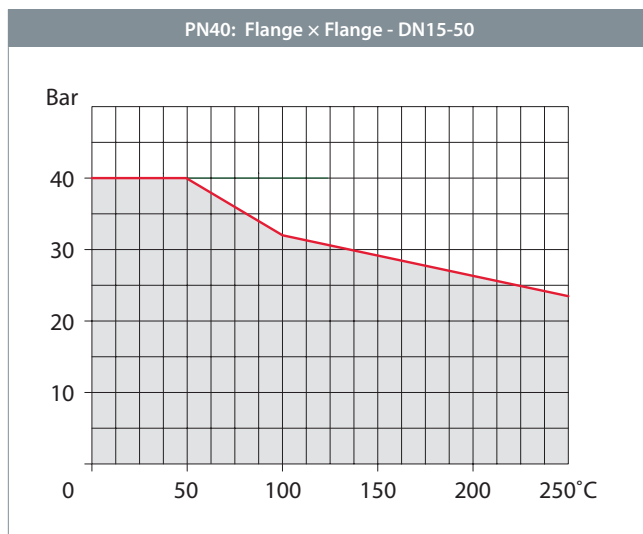
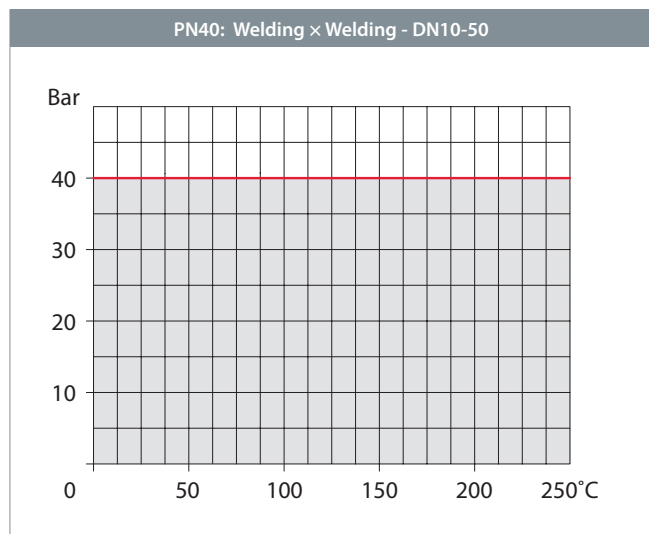

Pressure drop graph - DN10-200

Reduced bore

Pressure drop graph

Ball valve in fully open position.
Medium: water density in 1000 kg/m³

Definitions

Kvs: M³ water per hour at pressure drop 1 bar.

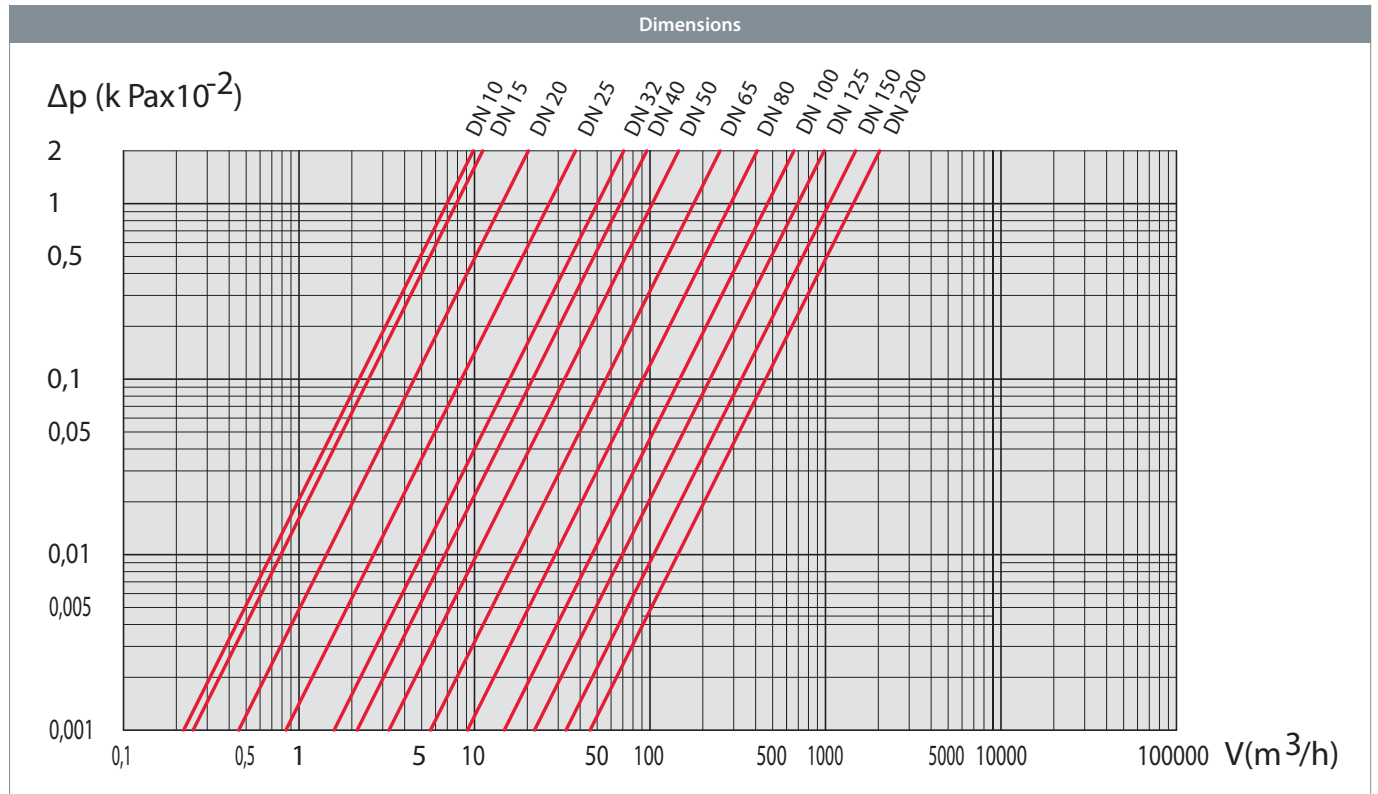

DN	10	15	20	25	32	40	50	65	80	100	125	150	200
Kvs	7	8	15	27	40	69	110	180	288	470	699	1046	1500

Operating torque - DN10-50, PN40

Reduced bore

Operating torque

The torque stated is for guidance only; it has been obtained by measuring on new ball valves. The torque is to be understood as the pull-off torque applicable for a closed, but recently activated ball valve.

The value stated may rise to a factor of 1.5 after a long period of inactivity.

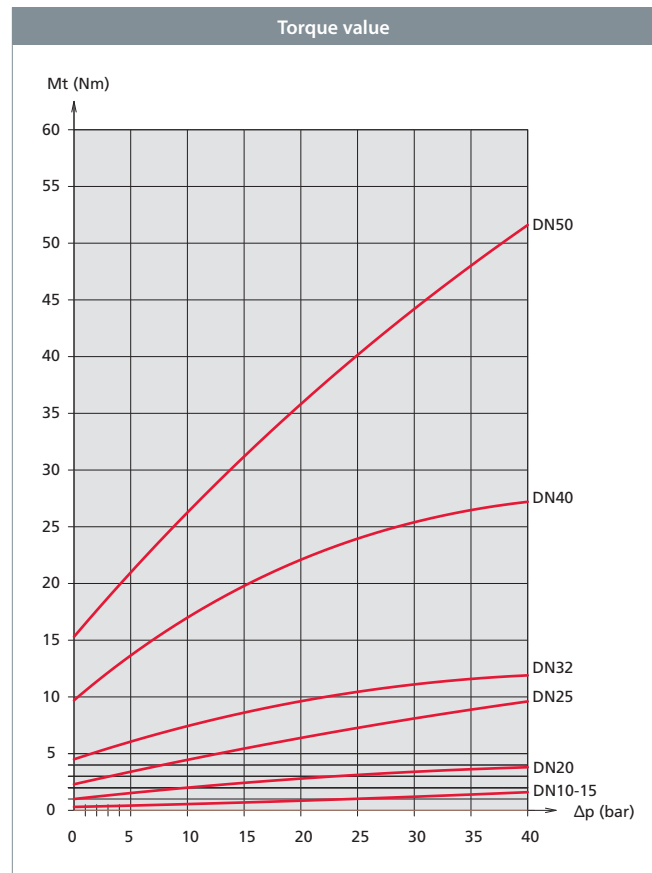

Operating torque - DN65-200, PN25

Reduced bore

Operating torque

The torque stated is for guidance only; it has been obtained by measuring on new ball valves. The torque is to be understood as the pull-off torque applicable for a closed, but recently activated ball valve.

The value stated may rise to a factor of 1.5 after a long period of inactivity.

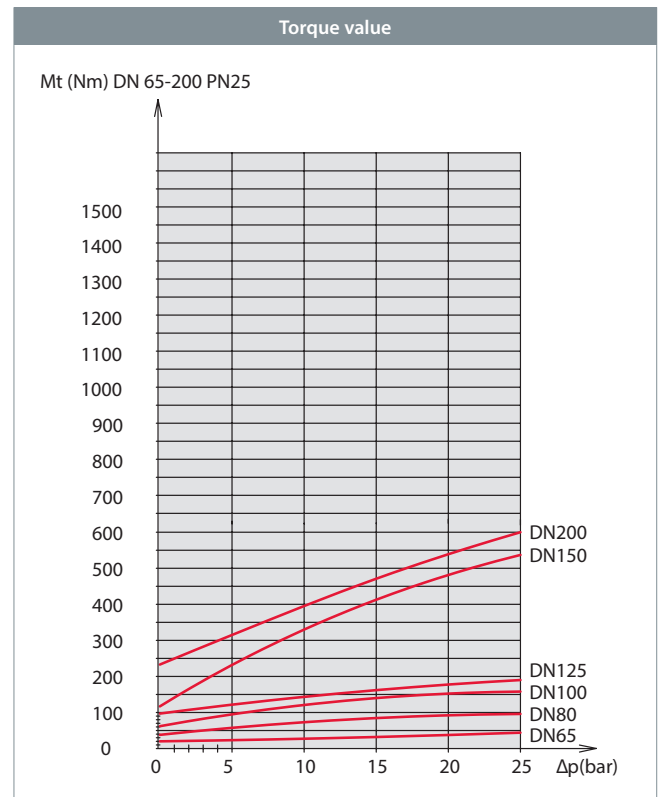

Connecting flange - DN15-50, PN40

EN 1092-1 - Type 11 B1 - Reduced bore

Description

Flangestandard.

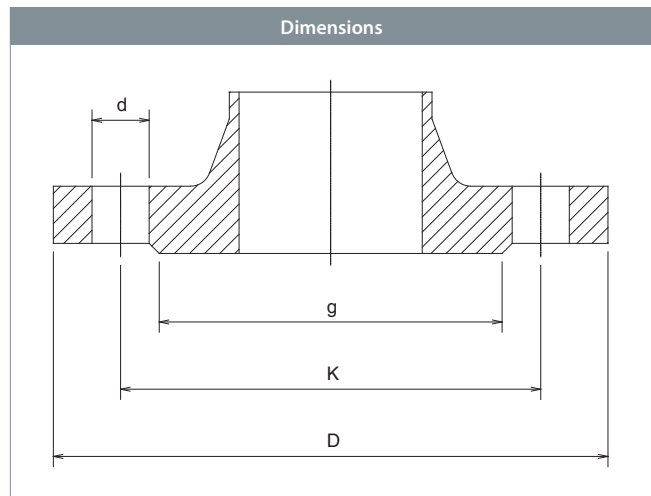

All dimensions in mm					
DN	D	K	g	d	No. of bolt holes
15	95	65	45	14	4
20	105	75	58	14	4
25	115	85	68	14	4
32	140	100	78	18	4
40	150	110	88	18	4
50	165	125	102	18	4

Connecting flange - DN15-200, PN25

EN 1092-1 - Type 11 B1 - Reduced bore

Description

Flangestandard.

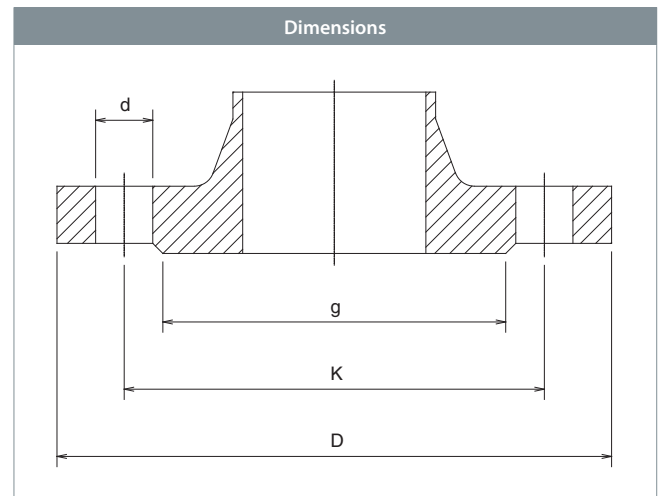

All dimensions in mm					
DN	D	K	g	d	No. of bolt holes
15	95	65	45	14	4
20	105	75	58	14	4
25	115	85	68	14	4
32	140	100	78	18	4
40	150	110	88	18	4
50	165	125	102	18	4
65	185	145	122	18	8
80	200	160	138	18	8
100	235	190	162	22	8
125	270	220	188	26	8
150	300	250	218	26	8
200	360	310	278	26	12

Connecting flange - DN15-200, PN16

EN 1092-1 - Type 11 B1 - Reduced bore

Description

Flangestandard.

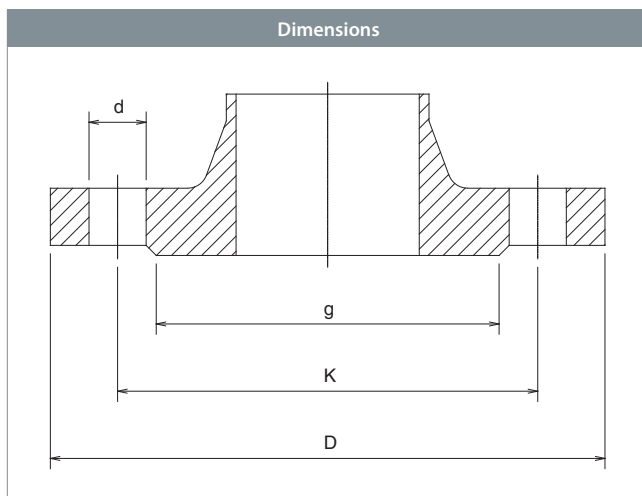

All dimensions in mm					
DN	D	K	g	d	No. of bolt holes
15	95	65	45	14	4
20	105	75	58	14	4
25	115	85	68	14	4
32	140	100	78	18	4
40	150	110	88	18	4
50	165	125	102	18	4
65	185	145	122	18	4
80	200	160	138	18	8
100	220	180	158	18	8
125	250	210	188	18	8
150	285	240	212	22	8
200	340	295	268	22	12

Valve actuator attachment - DN-65-200, PN10

ISO 5210 / ISO 5211 - Reduced bore

Description

ISO-flange for gear.

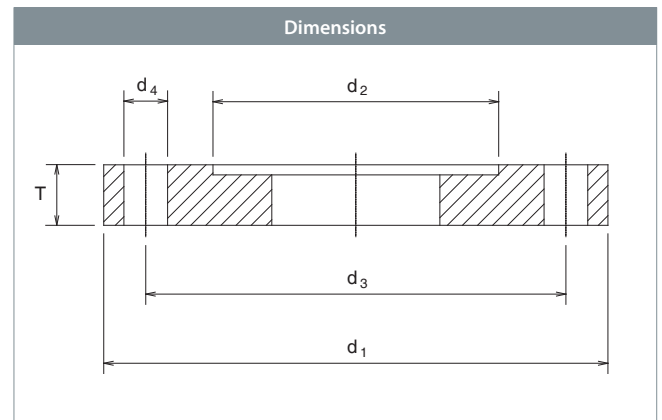

		All dimensions in mm					
To be used with	Flange type	T	d_1	d_2	d_3	d_4	No. of bolt holes
DN65-80	F05	12.5	65	35	50	7	4
DN100-125	F07	13.5	90	55	70	9	4
DN150	F10	14.5	125	70	102	11	4
DN200	F12	14.5	150	85	125	13	4

