

Central Cooling Water System

Self-Acting Actuation
Electric Actuation
Pneumatic Actuation

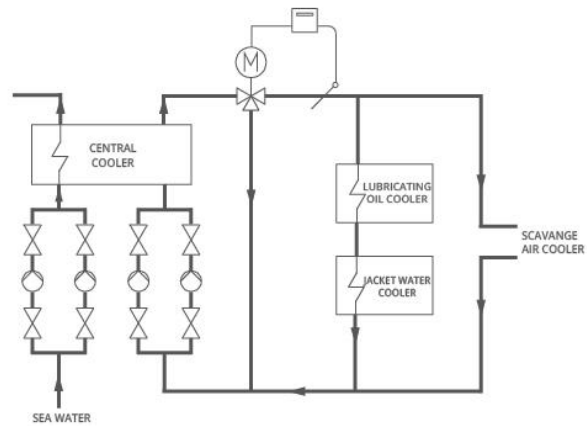

SOLUTION 2

(Principle only)



THERMOSTAT

3-WAY VALVE
DN 15 - DN 150

SOLUTION 6

(Principle only)



ELECTRIC ACTUATOR
3 POINT, ANALOGUE

3-WAY VALVE
DN 20 - DN 800

+



CONTROLLER ER2000
ELECTRIC

+



SENSOR PT100

SOLUTION 9

(Principle only)



PNEUMATIC ACTUATOR
SPRING CLOSE/OPEN

PNEUMATIC POSITIONER

3-WAY VALVE
DN 20 - DN 800

+



CONTROLLER
PNEUMATIC



TRANSMITTER
4-20 mA

SOLUTION 10

(Principle only)



PNEUMATIC ACTUATOR
SPRING CLOSE/OPEN

ELECTRO-PNEUMATIC
POSITIONER

3-WAY VALVE
DN 20 - DN 800

+



CONTROLLER ER2000
ELECTRIC

+



SENSOR PT100