



BROEN BUTTERFLY VALVES





Climate change is our common challenge

Energy efficiency is one of the greatest challenges of our times and for district energy BROEN delivers ready solutions to meet the globally rising demand for energy efficiency.

Based on the heritage from leading edge innovations in Danish District Heating, BROEN offers the most comprehensive range of proven valves for distribution and transmission of district heating in residential, commercial and industrial applications.

BROEN is your assurance of energy efficiency, reliability and low cost of ownership.

Our brand is our promise.

ABOUT BROEN

In 1948 Poul Broen established the company BROEN, which was among the pioneers, when district heating took off in Denmark. In 1982 the BROEN Ballomax® ball valve for district heating was launched. We strive to develop and improve products, that use nature's resources as efficiently as possible.

In 1993 BROEN was acquired by Aalberts Industries and today we have more than 15,000 colleagues operating from more than 200 locations in more than 30 countries. Aalberts Industries (AALB) is listed at the EuroNext Stock Exchange, NL

VISION AND VALUES

Our vision is simple: Be the best in valve technology. Strong values are the foundation for our business and with the same shared vision they link us together as one company across borders and time zones on 3 continents.

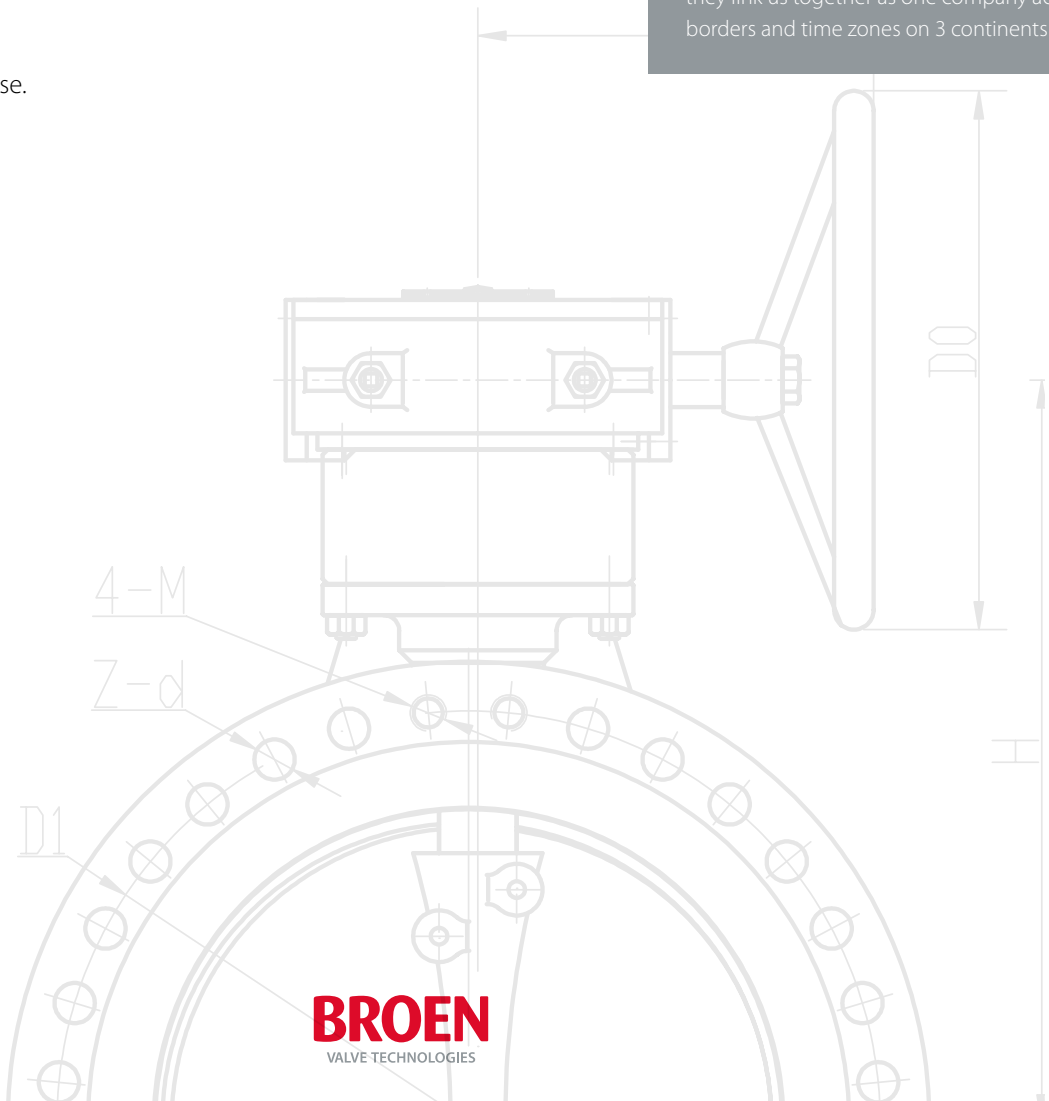

BROEN Butterfly valves

BROEN triple eccentric butterfly valves for district heating offer a safe and modern construction for use as a shut-off valve and regulating valve in district heating and district cooling systems, but is also in operation in oil, gas and steam applications.

The triple eccentric butterfly valves have a metal/metal sealing available. This concept means there is no traffic friction during opening and closing of the butterfly valve. The disc loses contact with the seat immediately after the start of opening.

The valve features Class A tightness in both flow directions at a low closing torque and efficient opening at the maximal differential pressure. This secures a long life of the seal.

The safe and robust construction requires minimal service, and any gear or actuators can be changed without the valve being removed.

In addition to its cut-off function this valve may be used as a regulating (control) valve. The mechanical worm gearboxes mounted on the butterfly valves are fitted with a disc opening angle indicator.



- All CE-marked valves are approved according to PED 2014/68/EU - module H
- Triple eccentric butterfly valve with metal/metal sealing
- Highest Class A tightness - EN 12266
- No periodic service
- ISO 5211 flange enables switch of gear or actuator without removing the valve from the pipeline
- Vertical and horizontal installation
- Temperature -30 ° C to + 425 ° C

BROEN triple eccentric butterfly valves

DN80 - DN2000

PN16 - PN25 - PN40 on request

Heating - Cooling - Steam



Type AKW – Interflanged Wafer

Connection flange according to ISO 5211.

DN 80-1200 | PN16 - PN25



Type AKFL – Flanged

Connection flange according to ISO 5211.

Mounting flange according to EN 10025-2.

DN80-2000 | PN16 - PN25



Type AKBW – Welded

Connection flange according to ISO 5211.

DN80-2000 | PN25

ISO 9001
EN 12266

100% quality control

Gear and actuation

Worm gearbox as a standard.

Electric, pneumatic- or hydraulic actuators available on a request:

- AUMA electric actuators
- REGADA electric actuators

Together with our comprehensive range of BROEN valves, actuators, gears, extensions and hot tapping tools, BROEN offers complete solutions for district energy.



BROEN triple eccentric butterfly valves

Tmax: -30°C to +350°C

Tmax: -30°C to +425°C on request

DN80 - DN2000

AKW - Wafer

AKFL - Flanged

AKBW - Welded

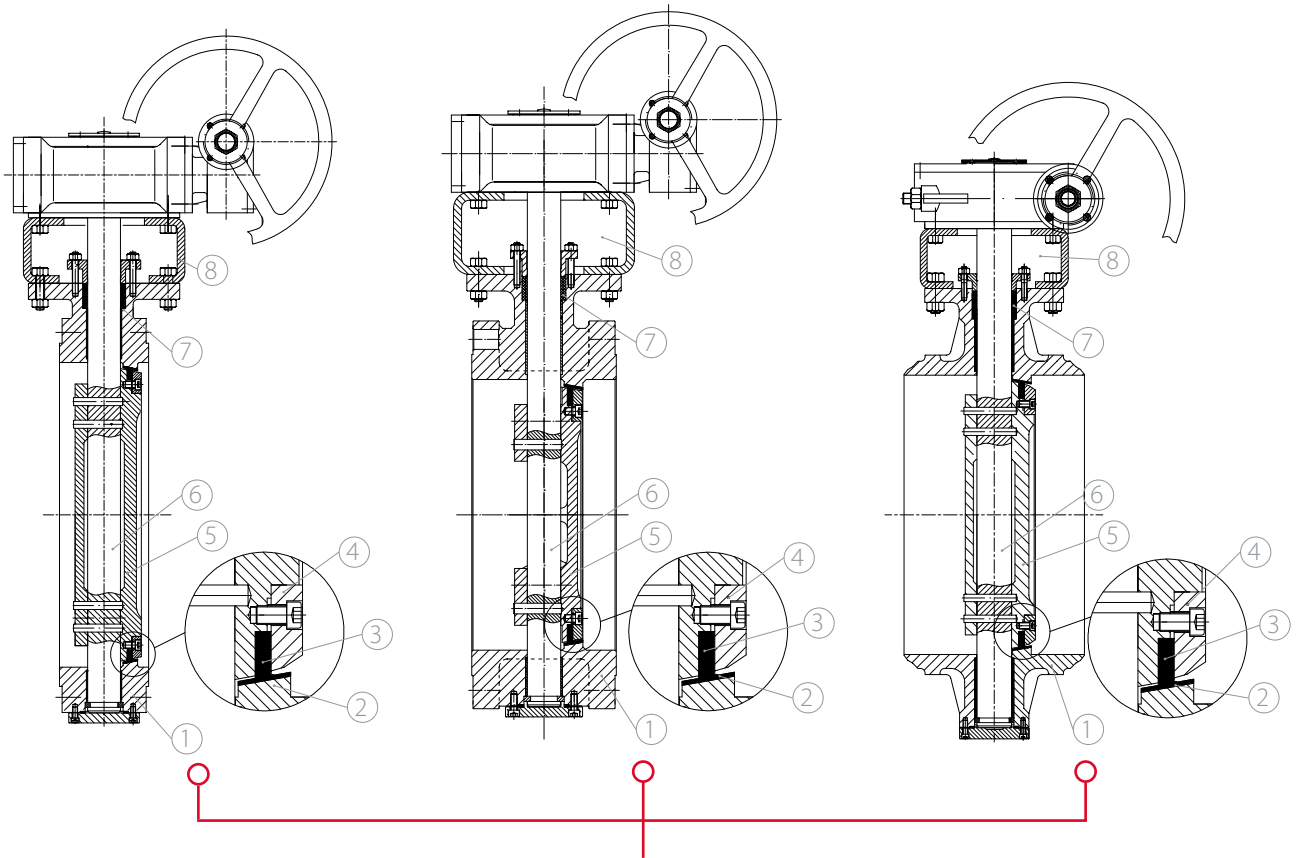

1. Valve body

Cast steel ASTM A 216 Grade WCB.

On request: AISI 351 CF8 or AISI 351 CF8M.

2. Sealing seat

D507Mo (stellite).

On request: 1.4308 - AISI 304 (stellite) or 1.4408 - AISI 316 (stellite).

3. Seat - Lamela

1.4301 - AISI 304 and graphite.

On request: 1.4401 - AISI 316 + grafit.

4. Ring

Steel \approx 1.0460 - AISI 105.

On request: 1.4301 - AISI 304.

5. Disc

AISI 216 Cast steel WCB.

On request: 1.4308 - AISI 351CF8 or 1.4408 - AISI 351CF8-m.

6. Shaft

AISI 564 630.

On request: AISI 182 XM-19.

7. Gland inserts

Grafit.

8. Actuators

Worm gearbox as standard.

On request: Electric-, pneumatic-, and hydraulic actuators.

Operation

ISO flange ISO 5211.

BROEN butterfly valves

Kv flow coefficients

DN [mm]	80	100	125	150	200	250	300	350	400	450
Kvs [m ³ /h]	164	250	414	682	1.300	2.200	3.370	4.432	6.411	8.660

DN [mm]	500	600	700	900	1000	1200	1400	1600	1800	2000
Kvs [m ³ /h]	10.320	16.012	25.235	3.177	54.201	76.724	100.862	138.000	179.000	223.000



Ever since BROEN was established
our passion for valve technology has been
a major part of our core competences.

Our brand is our promise.

BROEN Engineered Valve Group

For more than 70 years BROEN has been the global leader in the development and production of valve technology for the control of water, air, gas and oil. BROEN delivers complete solutions for HVAC building installations and is a leading supplier of district energy valves.

We know application and valve technology in depth and in close dialogue with our customers and partners all over the world we create value and reliability with proven valves offering full quality assurance.

BROEN is headquartered in Assens, Denmark and is part of Aalberts Industries NL.

Read more on: www.broen.com

BROEN Group locations

Headquarters in Assens, DK

Sales- and productions sites ●

BROEN A/S, Assens (DK)
BROEN SA, Dzierżonów (PL)
BROEN LLC, Kolomna (RU)
BROEN INC., Houston (US)
BROEN OIL & GAS, Suchy Las & Rogoźno (PL)
BSM Valves B.V., Breda (NL)
Clorius Controls, Dzierżonów (PL)

Sales companies and offices ○

BROEN, Assens
BROEN, Stockholm
BROEN, Helsinki
BROEN SEI, Romania
BROEN, Beijing
BROEN, Singapore
BROEN, Dusseldorf
BROEN, Moscow
Clorius Controls, Copenhagen
Clorius Controls, Shanghai



BROEN A/S

Skovvej 30, DK-5610 Assens, Denmark
Tel. +45 6471 2095 | Fax +45 6471 2495
broen@broen.com | www.broen.com