

BROEN

VALVE TECHNOLOGIES

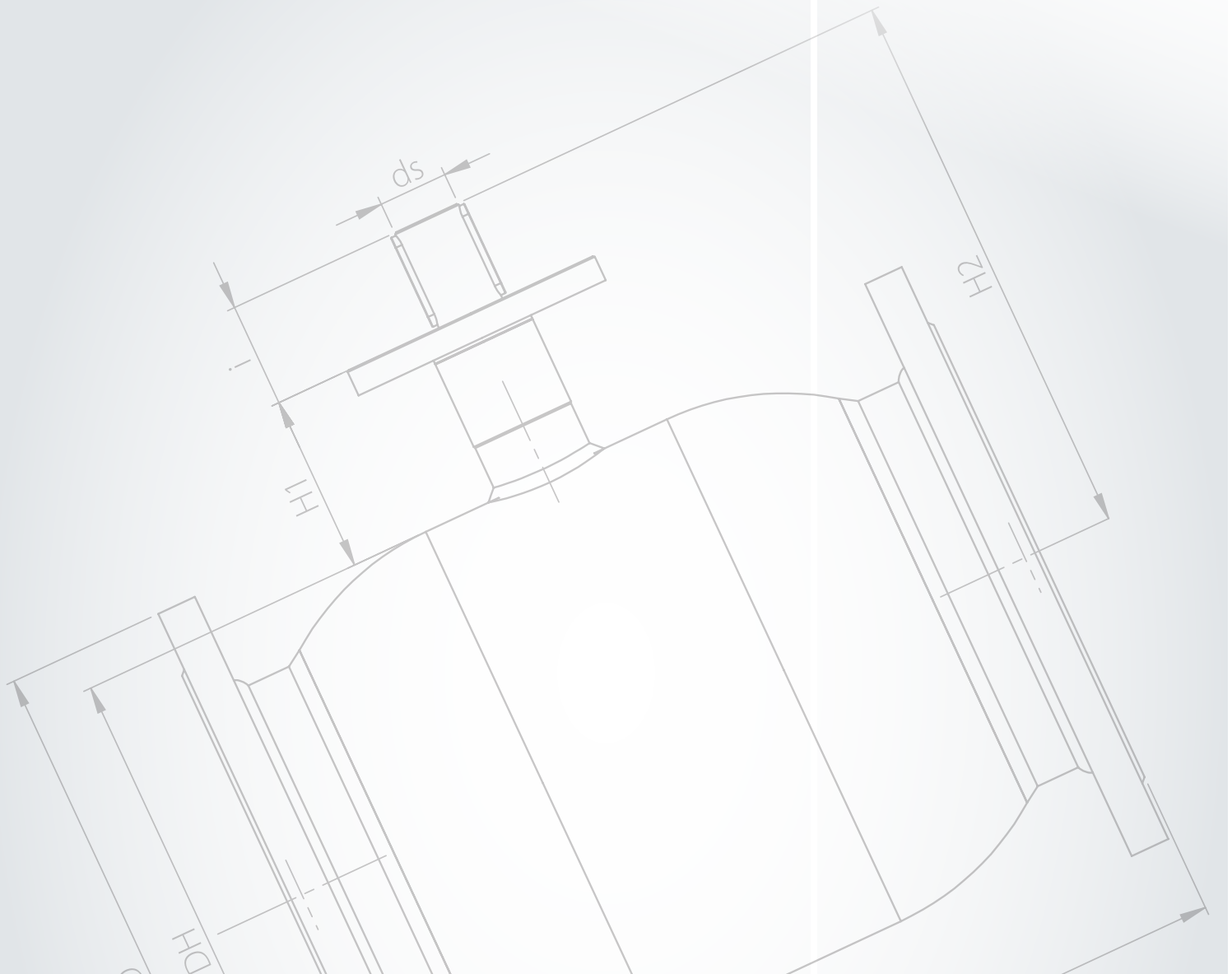

BROEN BALLOMAX[®] USER MANUAL

STANDARD BALL VALVES

VERSION 1.0

Ballomax[®]

ENERGY EFFICIENCY - DESIGNED TO LAST

Read more in the chapter "General information" on page 4.



Warning! Media can be hot and cause burning.
Do use safety goggles and gloves.

Read more in the chapter "Installation and welding" on page 7.



Warning! Wrong installation can result in several damage or that the valve is not functioning correctly. These general instructions do not cover all possible operating scenarios. For a more specific guidance about the usage of the valve or its qualification at the desired use, please contact BROEN.

Read more in the chapter "Change of gasket set" on page 31.



Warning! Media can be hot and cause burns.
Use safety goggles and gloves.

Content

BROEN Ballomax[®] User manual

1. General information.....	4
2. Transportation and storage.....	5
3. Instructions and precautions before installation and operation.....	6
4. Installation and welding.....	7
5. Commissioning and use	8
6. Service	9
7. Maintenance.....	9
8. Scrapping.....	10
9. Appendix	11

BROEN Ballomax[®] – further useful information

10. Mounting and disassembly of gears on a valve as well adjustment....	12
11. User Manual for BROEN Ballomax[®] hot tapping tool.....	16
12. User Manual for BROEN Ballomax[®] branching valve	20
13. Instructions for transportable gears.....	22
14. Flexible extensions and planetary gear for underground valves.....	25
15. Change of gasket sets.....	31

1. General information

BROEN Ballomax® Steel ball valves

BROEN Ballomax® is designed with highest possible safety and functionality in mind, but we recommend reading this manual thoroughly.

The technical data is not binding and can be changed without any notice. Please see our general terms and conditions. Further information can be obtained upon request. It is the responsibility of the project owner and installer to choose products suitable for the intended purpose and secure that pressure data and performance data is not exceeded. Updated installation manuals apply.

The entire system should be depressurized and emptied before any kind of removal, change or repair of a single component – no matter if the components are defective or not.

BROEN Ballomax® ball valve is intended for installation in heating-, cooling- and district heating- installations with treated water, that does not corrode neither carbon steel nor materials in the O-rings or seals.

The valve house is made in carbon steel and the stem and ball are made in stainless steel.

The ball seats are made of carbon reinforced Teflon (PTFE). The stem stuffing box is done with FPM- (Viton) and EPDM- O-rings.

The valve is tight in both directions and can be mounted in both directions. Local legislation must always be observed.

Approvals

BROEN Ballomax® ball valves in steel are approved according to the demands in (PED) 2014/68/EU for pressurized equipment, module H. Module H is the module for complete quality control.

Quality management

BROEN A/S has been ISO 9001 certified since 2001:2015.

2. Transportation and storage

It is important to check if the valve or its parts has been damaged during transportation. If there are any transportation damages BROEN recommends receiving the delivery and then immediately contacting BROEN.

BROEN recommends to control that the delivery is as agreed – number, size, type and equipment and etc.

Information about damages, defects or irregularities according to the agreement should immediately be informed to BROEN.

Store the valve in a clean and dry place before installation. Do not remove the protection caps before immediate installation.

Use lifting straps when lifting larger valves. Do not lift the valve in its actuator, stem or handle (Fig. 1, 2 & 3).

If in doubt about the weight of the valve to be lifted, you can see its weight in the Ballomax[®] catalogue or on BROEN's homepage – www.broen.com.

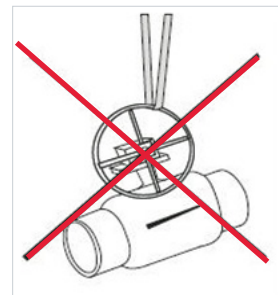

Fig. 1.

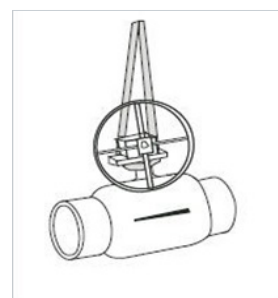

Fig. 2.

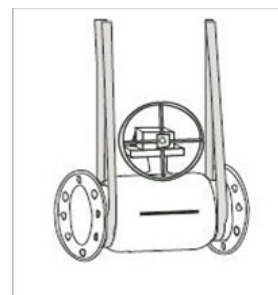

Fig. 3.

3. Instructions and precautions before installation and operation

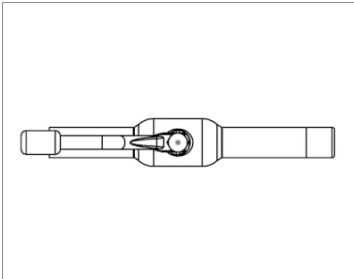

Fig. 4.

Present instructions should be carefully reviewed before mounting and operation of Ballomax® ball valves:

- Control that the valve is suitable and approved for the used media and the desired application. The valve is not suitable for steam! Here a valve suitable for high temperatures is to be used.
- Operate the valve, if possible, to ensure that the valve is not defective from storage or transportation.
- If the valve is used as an end valve in the pipeline, there has to be installed a pressure tight ending or blind flange after the valve and the valve is to be left in the open position (Figure 4).
- In order to ensure safe operation the manual gear or actuator cannot be removed or dismantled, without special precautions are taken, if the valve is under pressure and/or there is a flow.
- BROEN recommends, that the valve is installed in the pipeline with minimal vibrations. In the installation it is recommended to avoid stress and to relieve the valve for exposed longitudinally pressure and tensile load.

4. Installation and welding

Welding

The pipe line is to be cleaned thoroughly before the installation of the valves, as any impurities can damage the surface of the valve and seals.

Do not remove the manual gear or actuator from the valve unless it is absolutely necessary. In the event the manual gear or actuator is to be removed during or after the installation, then contact BROEN customer service or see instructions in the chapter "Instruction for mounted gear".

Electric welding (TIG, MIG) is recommended for all BROEN Ballomax[®] ball valves in steel. Valves larger than DN150 should always be welded in the pipe line by means of electric welding.

Do not overheat the valve during the welding – there is a risk for damage of the seals. It is recommended, that the welding is done by qualified personnel.

Cool the valve (after welding) before normal use. The valve should only be operated, when the valve is cooled sufficiently.

The welding is only to be done on the ends of the valve and not on the body of the valve, as this will damage the seals in the valve.

For further information refer to the guidance on the valve.

The valve can be placed in both vertical and horizontal position, and during the entire welding process it should be noticed, that the valve must be in open position.

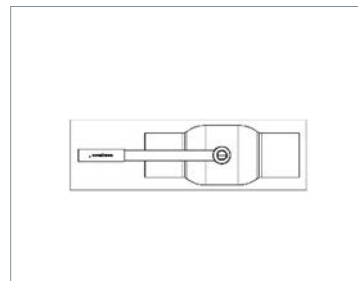

Fig. 5.

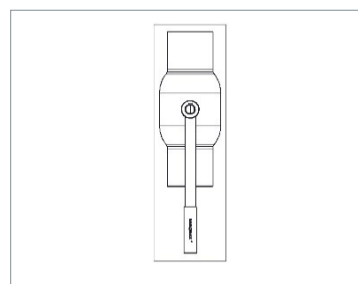

Fig. 6.

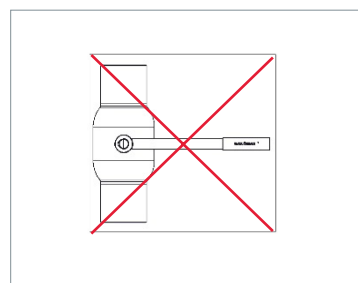

Fig. 7.

Welding of larger valves \geq DN 200 full port / DN 250 reduced port.
The valve must remain open during welding to protect the ball.

At risk of overheating there should a pause in the welding process.

The ground connection must not be connected to the valve.

Flange mounting: The valve should only be mounted by qualified personnel and follow valid norms and standards. The valve should be in open position during mounting in order to ensure, that dirt and coatings do not ruin the surface of the seals. The mating surface of the flange on the pipe should be parallel to the mating surface of the valve. The centerline of the valve and the pipeline should also be correctly aligned. The length of the valve should be the same as the length between the flanges in the pipeline also taking account the thickness of the gaskets. The flanges of the pipeline should be compatible with the flanges on the valve. For detailed information, please see standard EN 1092-1.

5. Commissioning and operation

After installation of the valve the pipe line should be flushed thoroughly. During this process the valve is to be open.

Testpressure at commissioning

If a pressure test of the system is needed, the following precautions are to be considered:

- The building of pressure is to be done slowly and gradually in order to prevent pressure surge and hammering.
- During the pressure test of the pipeline (1,5 x PN) the valve is to be in the open position.
- BROEN Ballomax® ball valves are designed to be fully open or fully closed. Control that the valve is either fully open or fully closed position against the endstop.
- Take care that the maximum and minimum temperatures, of the valve, is not exceeded! The maximum operating pressure and minimum-/maximum-temperatures are shown on the label of the valve.

6. Operation

Handle operated valves

When the valve is open the handle flush the pipeline. Fig. A.

Gear mounted valves

The valve opens when the gear is turned clockwise. Valves prepared for installation of gear/actuator. The position indicator at the end of the stem indicates the position of the ball in relation to the stem.

The opening and closing of the valves are to be done slowly and carefully in order to prevent pressure surge in the pipe line.

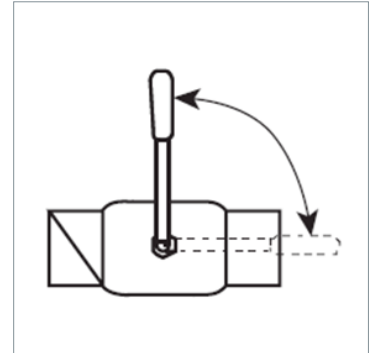

Fig. A.

7. Maintenance

The valves do not demand extra service under normal conditions, but to ensure correct function of the valves, it is recommended to open and close the valves once yearly.

Correct functionality of the valve demands correct quality of the water and installation. The valve house is made in carbon steel and is as such not resistant to corrosion.

Corrosion from the outside can be avoided by either installing the valve in dry environment or equip the valve with a watertight insulation or another surface protection (not oil).

The stuffing box in the stem is designed to last for the lifetime of the valve. In specially unfavorable conditions minor leakages can occur. This can be solved with a change of the o-ring, which can be done without draining the valve of pressure or media.

Be aware of all special conditions and contact BROEN if necessary.

If it is necessary to change O-rings on the stem, BROEN should be consulted for guidance and safety instructions.

Gasket sets:

Hexagon with dolly:

Size:		Item number:
DN20-80 RB	DN25-65 FB	600262
DN100 RB	DN80 FB	600263
DN125-150 RB	DN100-125 FB	600264
DN200 RB	DN150 FB	600269

ISO-flange:

Size:		Item number:
DN200 RB		600266
DN250-300 RB	DN200-250 FB	600265
DN400 RB	DN300 FB	600267
DN500 RB	DN400 FB	600268

8. Scrapping

Almost every part in BROEN Ballomax[®] valves are made of reusable materials. The type of the materials is described on the data sheet of each valve.

9. Appendix

Standard mounted flange for gears – ISO 5211

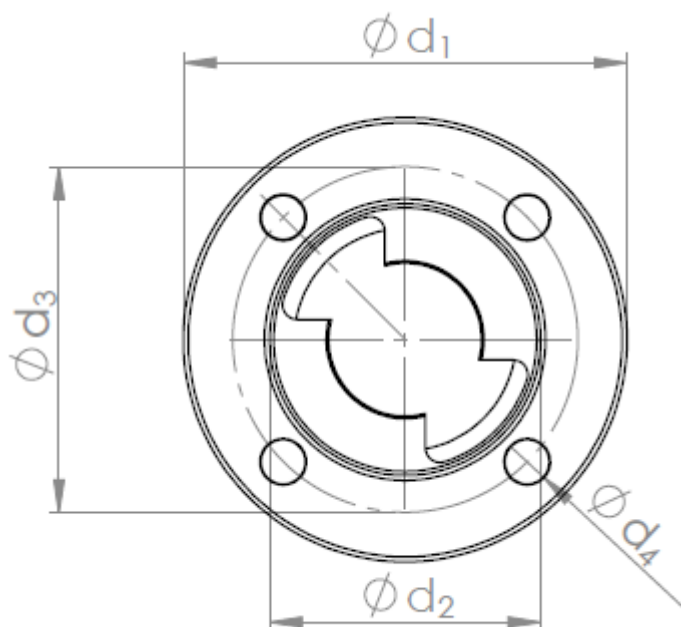

Reduced port

DN valve	Flange type	D1	D2	D3	D4	t	Boltholes
125	F07	90	55	70	9	13,5	4
150	F10	125	70	102	11	14,5	4
200	F12	150	85	125	13	14,5	4
250	F14	175	100	140	17	17,6	4
300	F16	210	130	165	21	23,5	4
350	F16	210	130	165	21	23,5	4
400	F25	300	200	254	17	27,5	8
500	F30	350	230	298	21	28,5	8

Full port

DN valve	Flange type	D1	D2	D3	D4	t	Boltholes
100	F07	90	55	70	9	13,5	4
125	F10	125	70	102	11	14,5	4
150	F12	150	85	125	13	14,5	4
200	F14	175	100	140	17	17,6	4
250	F16	210	130	165	21	23,5	4
300	F16	210	130	165	21	23,5	4
350	F16	210	130	165	21	23,5	4
400	F30	350	230	298	21	28,5	8

10. Mounting and disassembly of gear on a valve as well as adjustment.

Please read the instructions thoroughly before beginning of the procedures and contact BROEN, if there are any questions.

The valve is a shut-off valve. The valve is to be left in the fully open or fully closed position.

Normally the valve is delivered in fully open position. In fully open position the indicator line on the end of the stem is pointing in the longitudinal axis of the valve.

The operation of the valve (from fully open to fully closed position) is done by rotating the stem the maximum distance. The distance in gear and valve is 90°.

Note: BROEN A/S recommends, that the gear is mounted and adjusted before the valve is installed in the pipe line, while there still is free view to the ball inside the valve. Is the gear mounted and adjusted after the installation of the valve in the pipe line, then it is no longer possible to control, that the position of the ball is in fully open or fully closed position. Wrongly positioning of the ball can cause damage on the seats of the valve and leakage from the valve in closed position.

Disassembly of the gear from the valve

1. Close the valve.
2. Remove the four (or eight) mounting screws and lock washers.
3. Remove the gear from the valve.

Mounting of gear on the valve (handwheel or chainwheel)

1. Place the gear and the valve in the same position (both open or both closed).
2. Most gearboxes comprise a reduction cone, which is equipped with a key. If the reduction cone is supplied separately or falls out, the cone has to be fitted/placed correctly.
3. Choose the wanted mounting position of the gear box. Activate the gear box with the valve stem and put the gear box in position upon the valve.
4. Mount the gear box (and if necessary also on insulation gasket) upon the valve by means of the four (or eight) mounting screws.

Do not forget the lock washers!

Tighten the screws as shown in table A below.

Tabel A - Torque

Fastener dimension	M6	M8	M10	M12	M16	M20	M30	M36
Bolt dimension: Steel	8,5 Nm	20,5 Nm	41 Nm	71 Nm	170 Nm	350 Nm	1190 Nm	2100 Nm
Bolt dimension:: Galvanized steel (klass 70)	5,9 Nm	14,5 Nm	30 Nm	50 Nm	50 Nm	244 Nm	445 Nm	651 Nm

- Adjust the open and close position stop as shown in the following chapter "Adjustment of gear after mounting upon the valve".

Adjustment of the position end screws

Fig. T.1 overview of components.

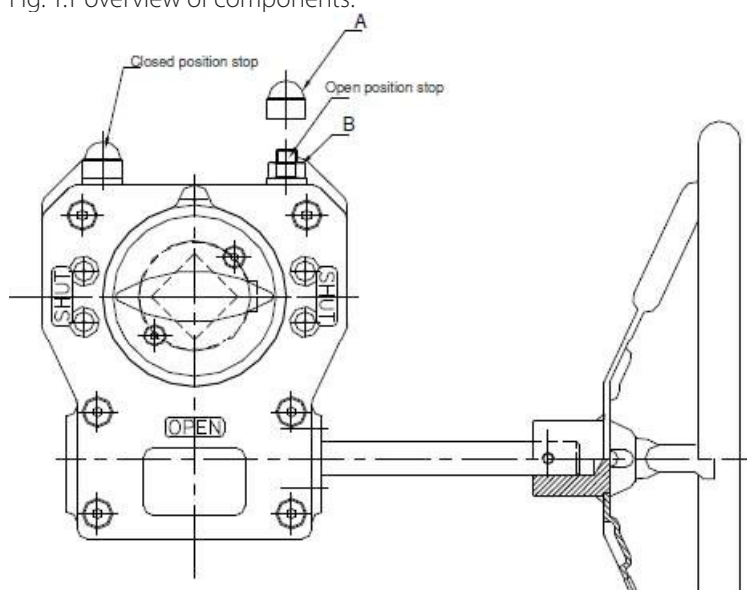

The open and close position stops prevent the actuator of rotating beyond the open and closed positions of the valve. Each stop can be adjusted. The stops are not preadjusted by the gear box manufacturer. We refer also to the instructions of the valve for specific demands of the closed position of the valve.

Adjustment of gear after mounting on valve

Size DN10-DN150

How to adjust the stop for closed position

- Remove the protection cap (A) from the counter nut on the stopscrew for the closed position.
- Loosen the counter nut (B) on the end screw for the closed position and loosen the end screw a few turns.
- Turn the handwheel (or another operating device) so the valve is in closed position.
- Turn the stopscrew for the closed position clockwise until there is a feeling of resistance from the end screw, when it is in contact with the gear in the actuator.
- Hold the end screw so it does not turn, when the counter nut (B) is tightened.
- Put the protection cap back (A) on the counter nut.

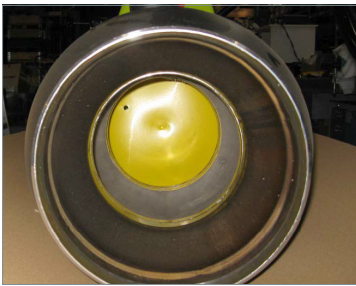

Fig. 8.



Fig. 9.



Fig. 10.



Fig. 11.

How to adjust the stop for open position

1. Remove the protection cap (A) from the counter nut on the end screw for the open position.
2. Loosen the counter nut (B) on the end screw for the open position and loosen the open screw a few turns.
3. Turn the handwheel (or another operating device), so that the valve is in open position.
4. Turn the end screw for open position clockwise until there is a feeling of resistance from the end screw, when it is in contact with the gear in the actuator.
5. Hold the end screw, so it does not turn, when the counter nut (B) is tightened.
6. Put the protection cap (A) back on the counter nut.

The exact position of the ball in open and closed position, is very important ensuring the tightness of the valve. If it is possible to see inside the valve, the position has to be controlled carefully.

Open position: The ball is exactly adjusted, so that the opening flush with connection ends and the seal rings of the valve seat.

Closed position: There should be full contact/overlap between the ball and the seal rings of the valve seat.

Size DN200 – DN500

First adjust the open position

1. Rotate the stem and ball counterclockwise  from closed position towards open position.
2. While rotating counterclockwise look inside the valve. Continue rotating counterclockwise until the ball is aligned up according to the seat gaskets of the valve. See figure 3.
3. Set the adjustment screw of the gear, so that the operation of the valve is limited to this position.

If the ball is rotated too far – see figure 9 – and a re-adjustment is necessary it is important that the ball is not aligned by rotating clockwise .

Do instead following:

1. Close the valve.
2. Align the ball again in open position by rotating the ball counterclockwise .
3. Readjust the adjustment screw.

Note: It is important that the open position always is adjusted by rotating the stem and ball counterclockwise  in order to avoid backlash in the gear and the valve, that disrupts the adjustment.

In cases where the disassembly or mounting of valves with electric actuators is needed – follow carefully the instructions in the guidelines of the actuator or contact BROEN.

Reduceret flow	Full flow	Maximum output torque from gear [Nm]
DN250	DN200	1500
DN300/350	DN250	3000
DN400	DN300/350	6500
DN500	DN400	16000

Ventil	DN250	DN300 & DN350	DN400	DN500
Mål	21 mm	28 mm	34 mm	43 mm

11. User manual for BROEN Ballomax® hot tapping tool.

Fig. 1

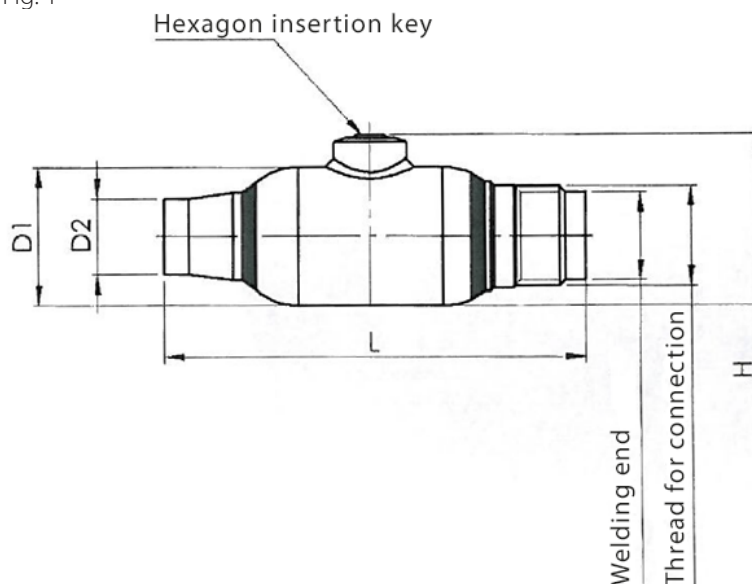

BROEN Ballomax® hot tapping tool

DN	Vare nr.	L	D2	H	D1	Tilsvej- sende	Gevind f. kobl.	5kt. Nøgle	DIA. Kugle	Bor dia.	Anbefa- let RPM
15	68102015	127	ø23	53	ø42,4	ø21,3	G 7/8	5mm	ø15	ø14	400
20	68102020	127	ø23	53	ø42,4	ø26,9	G 7/8	5mm	ø15	ø14	400
25	68102025	143	ø28	63	ø51	ø33,7	G 1 1/8	5mm	ø20	ø19	300
32	68102032	145	ø33	68	ø57	ø42,4	G 1 1/2	5mm	ø25	ø24	300
40	68102040	178	ø42	96	ø76,1	ø48,3	G 1 3/4	7mm	ø32	ø30	250
50	68102050	198	ø52	107	ø88,9	ø60,3	G 2 1/4	7mm	ø39	ø37	200
65	68102065	205	ø54	118	ø108	ø76,1	M64x2	8mm	ø49	ø48	200
80	68102080	200	ø80	137,5	ø127	ø88,9	M76x2	8mm	ø63	ø60	150
100	68102100	225	ø97	163,2	ø152,4	ø114,3	M95x2	*10/12mm	ø78	ø76	125

Important:

If hot tapping valves are used on systems with temperatures over 100°C, steam can be generated, which is led out through the flush valve. Be aware of the danger of burn.

After welding of the hot tapping valve upon the pipe line it is recommended to make a tightness test of the weld. For this a test plug is needed and this is supplied with the case.

Hot tapping procedure for DN15 and DN20 BROEN Ballomax® hot tapping valve:

Put a 14mm drill in the drilltool and pull the drill all the way back in the house. The drill can if necessary be held by the means of the stuffing box screw.

Mount the hot tapping tool upon the valve. It should be ensured, that the hot tapping valve can be closed. Open the hot tapping valve and push the drill to the contact with the pipe line.

Mount the drilling machine. A hose is mounted on the flush valve in order to lead the district heating water and chips away from valve.

Open the flush valve.

Decide the revolutions of the drilling machine from the delivered table.

The drilling should be done with frequently interruptions to protect the drill and to secure, that only small chips are created, which much easier can be flushed away.

When the drilling is complete, the drill is pulled all the way into the hot tapping tool. The hot tapping valve can now be closed. If a chip blocks the close of the valve, the ball is turned 180° back and the valve is closed. The hot tapping tool can now be dismantled.

The hot tapping installation is now completed.

Hot tapping procedure for DN25, DN32, DN40 and DN50 BROEN Ballomax® hot tapping valve:

Each valve dimension uses a coupling in connection with the hot tapping tool. The same coupling is also used in connection with the test plug for the tightness test.



The enclosed table shows what dimensions of drill can be used.

A drill extension can be used for both types of drill holders.

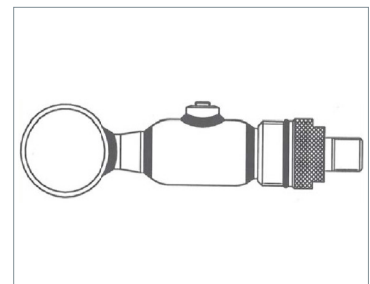

Fig. 12.

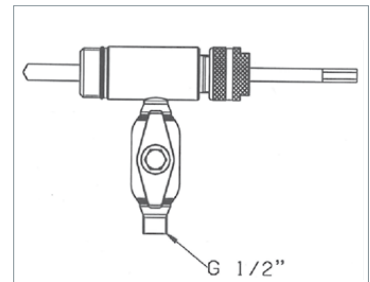

Fig. 13.

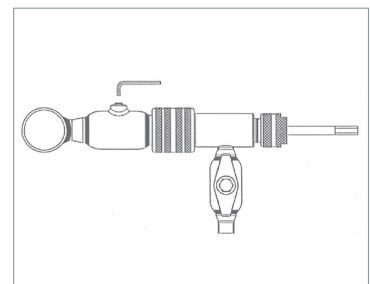

Fig. 14.

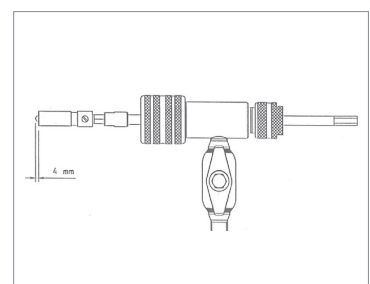

Fig. 15.

The drawing (Fig. 16) shows the hot tapping of a DN25 hot tapping valve.

Mount the coupling on the hot tapping tool. Mount the correct drill. Remember that the pilot drill should only be showing app. 4mm. Pull the drill all the way back in the hot tapping tool.

Mount the hot tapping tool on the valve. It is to be ensured that the hot tapping valve can be closed. Open the valve full and push the drill forward until contact with the pipeline. Open the flush valve. Mount the drilling machine.

Decide the revolutions of the drilling machine from the enclosed table. The drilling is executed with a light pressure on the drill and with frequent interruptions to protect the drill and release the chips. When the drilling is done, the drill is pulled all the way into the hot tapping tool.

It is important that fluid pressure is kept on the drill to secure that the drilled part remains in the cup drill. The hot tapping valve can be closed. If a chip prevent, the valve in closing, the ball is turned 180° back and the valve can be closed.

Fig. 16.

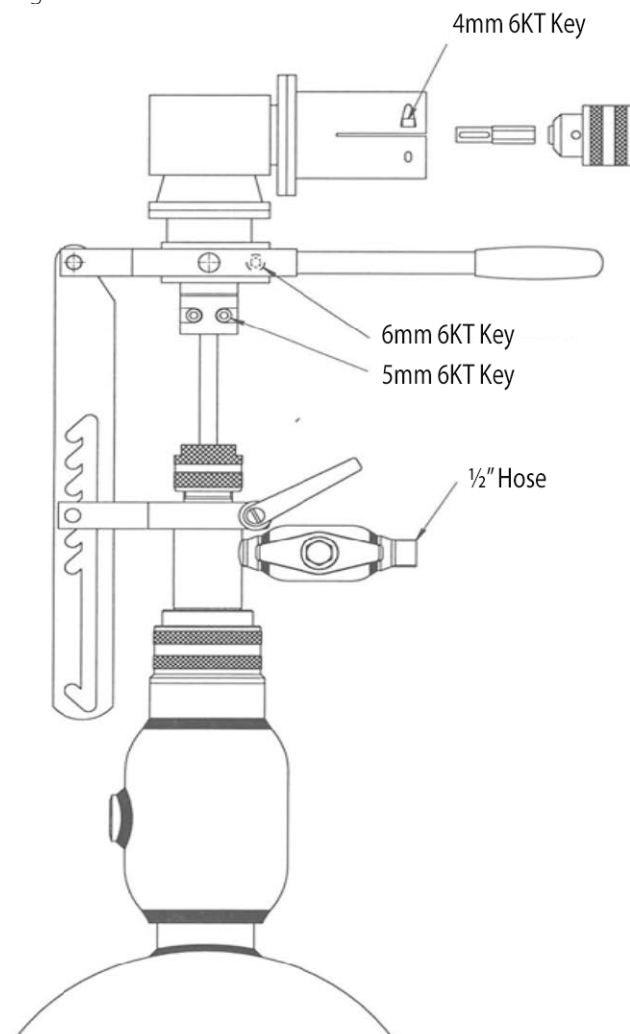

Hot tapping procedure for DN65, DN80 and DN100 BROEN Ballomax® hot tapping valve.

These valves have an internal thread for connection of the hot tapping couplings.

The mounting procedure for the connection of the hot tapping tool is similar to the procedure used for the smaller hot tapping valves.

It is recommended to use the delivered reduction gear and tension unit for hot tapping with the mentioned valves and use a drilling machine with revolution control. Hereby a controlled drill operation is obtained with a central pressure on the cup drill.

It is very important, that the recommended revolutions of the cup drills are respected. Reduction gear ratio: 7:1.

The figure describes the lineup and how the different components are situated. In the transport case all the relevant hexagon keys for the mounting and operation of the different hot tapping valves are found.

IMPORTANT:

1. The pilot drill is not to be further out than the cup drill (max. 4mm). Hereby it can be assured that the valve can be closed, when the cup drill is pulled all the way back.
2. The flush valve is to be remain open during the hot tapping process to ensure, that the drilled part is kept in the cup drill, until the valve can be closed.

NB: The appearance of the holder of the cup drill can change appearance pending on the manufacturer.

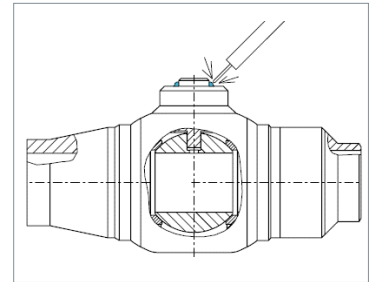

Fig. 17.

12. User manual for BROEN Ballomax[®] branching valve

BROEN Ballomax[®] branch valves are used in underground pipe lines, where extensions of strings are planned.

The branch valve can only be mounted on systems, which are without media and hereby pressure less. If the pipeline which upon a valve is to be welded is under pressure, then the BROEN Ballomax[®] hot tapping valves are recommended to be used.

The branch valve is not a traditional service valve and if there are more operations to be done, it is recommended to use BROEN Ballomax[®] shut off valves instead.

The installation is done by firstly exposing a piece of the pipeline. A hole of the size of the connection of the branch valve is drilled. After installation a pressure test is carried out to test the tightness of the welding.

A piece of a pipe is welded on (welding ends) or mounted (threaded ends), which is closed with a plug. After that, it is ensured that the valve is in fully open position. The branch valve is mounted on the pipe line and if it is not to be used immediately, it can be insulated and wait until it is to be used. If the valve is not to be used for longer period of time, BROEN recommends that the valve is not used as an endstop valve, but that a plug is mounted after the valve. A longer period of time means exceeding 1 year before use. The valve can begin leaking with wrong use, as the seats will be damaged from pressure changes in the pipe line over time.

NB: The branch valves are not be used as end stop valves.

The stem has a notch as position indication of the valve.

When the extension is to be used, the branch valve is closed for work on the pipe line extended. After work on the pipe line the branch valve is reopened and the new pipe line is in use.

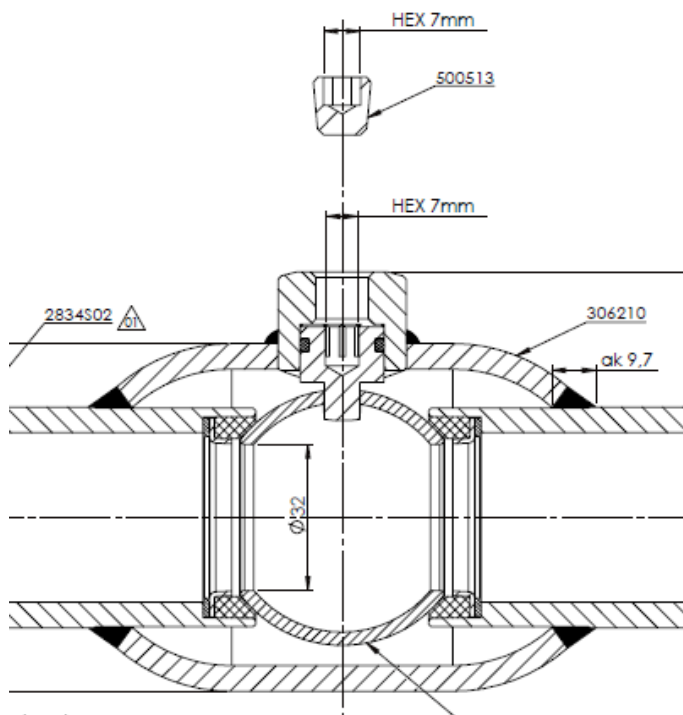

Instructions for BROEN Ballomax[®] hot tapping valves and branch valves

The hexagon for operation of the valve is placed under the conical plug. This hexagon is marked with the direction of the ball. The operation is done over 90° from open to close. The operation is done with a hexagon key.

Hot tapping valves and branch valves are not equipped with end stops.

BROEN recommends, that the top conical pipe plug for a short time can be tightened with PTFE tape and Locktite 577.

After the final operation the top of the valves are to be welded shut permanently.

13. Instructions for transportable gears

BROEN transportable gears is available in two sizes, MP II and MP III.

MP II with the 70mm hold has a maximum torque of 800Nm and with a 90mm hold a torque of 1800Nm.

MP III with the 90mm hold has a maximum torque of 6000Nm.

MP II gear components



MP III gear components

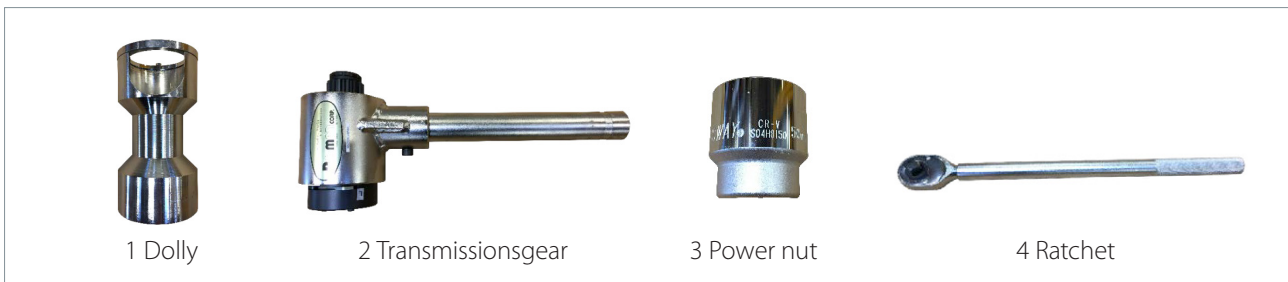

Preparation:

1. The transmissiongear (2) is put together with the dolly (1) and depending on the use the 70mm dolly or the 90mm dolly is to be used. The power nut is placed in the dolly.
2. Place the hold (1) together with the transmissiongear (2) and power nut (3) on the dolly of the valve. Turn by hand the input on the transmissiongear until the power nut falls in place upon the hexagon of the valve. Take care that all parts are fitted together on the valve.
3. Place the ratchet (4) on the transmissiongear (2) and extend the lever to increase the torque input to the gear. On the ratchet the desired direction is chosen.
Right – clockwise – The valve is closed.
Left – counterclockwise – The valve is opened.
4. To ensure an easier transfer of torque to the valve, the transmission function on the transmission gear has to be activated. In order to activate this transmission the top of the gear should be raised so the two edges are clear.

IMPORTANT:

If you do not secure that item 4 is fulfilled the transmission could be 1:1 and the operation of the valve could become more difficult.

Opening and closing of the valve:

Close:

The turning direction is clockwise. To release the ball from the seals and not damage the seals, you should first turn the valve so far, until you feel a certain resistance in the ratchet. The occurred torque in the ball will then loosen the ball from the seals and after a short while you can continue turning clockwise to close the valve.

You continue until you again feel an increasing resistance in the ratchet. Gear and stem have now stopped against the mechanical stops. The valve is now closed and secured from reopening by itself.

Open:

The turning direction is counterclockwise. The opening of the valve happens in the same way, as when it is closed.

On the stem of the valve there is a position indicator showing the position of the ball, which is either open or closed. In this way it can be checked if the valve is closed when the indication shows a closed valve.

Deviations from this can cause damage on the seals and the ball.

Transportable gear:

Type:	Part number:
MPII (27/70)	66361100 060
MPII (50/90)	66361250 070
MPIII (50/90)	66361400 080

Measurements for MP11 and MP111 complete

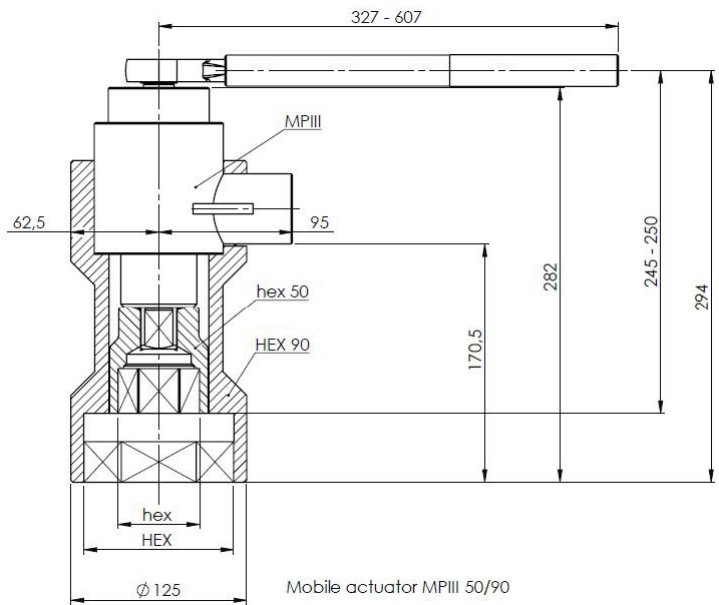
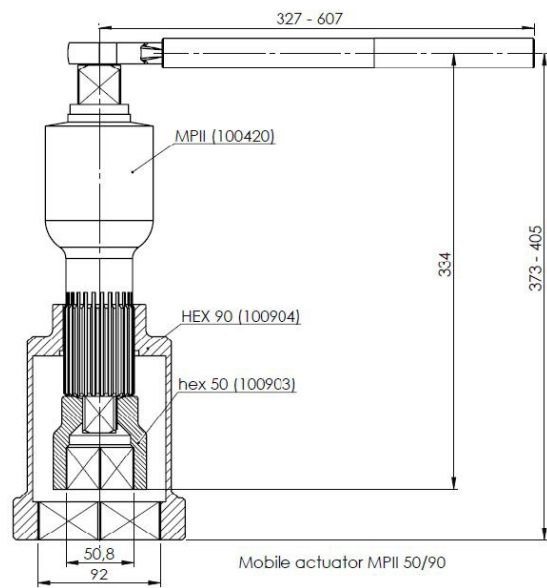
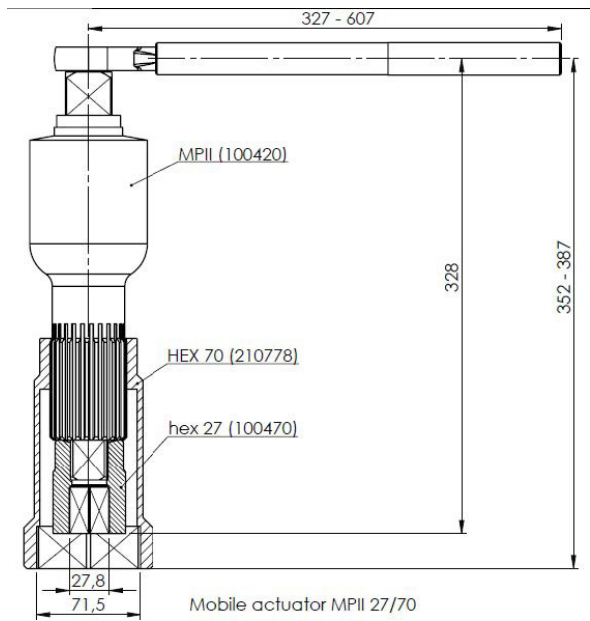

14. Flexible extensions and planetary gear for underground valves



Fig. 18.

Planetary gear is mounted on the valve from the factory. The planetary gear is hereby adjusted and equipped with a serial number.

The planetary gears belongs to the supplied valves and are not interchangeable. Correspondingly the hexagon on the valve can be extended with the flexible extensions 27/70 or 50/90 with standard lengths of 500mm, 1000mm and 2000mm. In cases where the standard length is not useable, the extension can be shortened.



Fig. 19.

Regulation of the length of the stem extensions

Illustrated parts and tools are also going to be used:



Fig. 21.



Fig. 20.

Length calculation of the stem extension:

NOTE: This manual is only valid for valves with reduced port. If needed for use on valves with full port, please contact BROEN.

Calculation example:

Adjustment of the standard extension (L=1000mm for a ball valve DN200)

Standard stem height on valve (SH): 585mm (The height from the centerline of the valve to the upper edge on the hexagon)

Requested total height (TH) – (depending on the buried depth of the valve): 1700mm, measured from the centerline of the valve to the upper edge of the well cover.

The wanted height from well cover to the upper edge of the operation square is normally 200mm.

The flexible extension is shortened with mm:

Type:	Reductions in X mm
TH=	1620 mm
Minus	-200 mm
FKV	1420 mm
SH=	585 mm
Y=	195 mm
X= (FKV – (SH+Y))	640 mm
ØSL = 1000 mm – X	360 mm

The adjustment of the length of the flexible extension

Usually the flexible extension is supplied with a position indicator strapped on the stem. This prevents it in displacing during transportation and slide away from the hexagon dolly on the valve. The position indicator is not used, when the planetary gear is used and can be removed by unscrewing the socket screws.



Fig. 22.

No.	Component
1	Stem
2	Position indicator
3	Socket screw
4	Hexagon dolly
5	Internal retaining ring
6	Socket screws



Fig. 23.

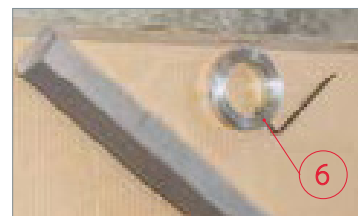

Fig. 24.

The shortening of the flexible extension:

In order to shorten the stem the internal retaining ring has to be removed. This is done by unscrewing the socket screws in the ring.

Reducing the hexagon dolly (the bottim part):



Fig. 25.



Fig. 26.

The surface of the cut should be protected with durable corrosion protection (e.g. Coldzinc paint, not part of supply).

The shortening of the stainless stem (the upper part) to the wanted length (\varnothing SL):



Fig. 27.



Fig. 28.

Preparation of retaining of the pipe of the hexagon dolly on the valve

Three holes of 8mm are drilled with an alteration of 120° on three sides of the pipe of the hexagon dolly. M8 nuts (part of supply) are welded on. The pipe of the dolly is retained with screws M8x15.

Alternatively:

Three threads are made with an alteration of 120° on three sides of the pipe of the hexagon dolly. The pipe of the dolly is retained with the supplied screws M8x15.

Corrosion protection has to be applied on the machined parts.

Transfer of the positions indicator on the upper part of the shortened stem

Mounting of the flexible extension on the valve.

1. The planetary gear is released from the valve by unscrewing the pointed screws on the gear.
2. Mounting of the internal retaining ring on the stem.
3. The extension stem is placed upon the stem of the valve and is retained by means of three screws.
4. The planetary gear is placed on the stem extension and is retained by means of pointed screws.



Remember to only loosen the lower pointed screws.

See next chapter for the reinforcement of the stem extension.

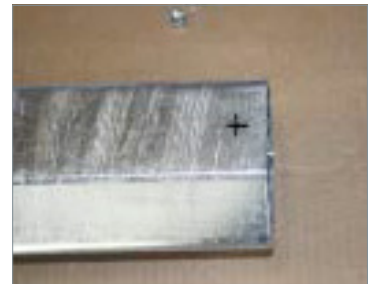

Fig. 29.



Fig. 30.



Fig. 31.



Fig. 32.



Fig. 33.



Fig. 34.



Fig. 35.
Measurement from upper edge of the stem.



Fig. 36.

NOTE:

The insulated protection pipe on the stem of the valve should be shortened (at least 50mm) in order to maintain the accessibility of the pointed screws.

Assembly guide of the reinforcement of the stem extension



Fig. 37.
Reinforcement.

After the shortening of the extension three holes are drilled with 120° on three sides.

Then the reinforcement is placed. Picture 39.

Hereafter the area for welding is marked. Picture 40.

Prior to the welding the zinc protection is to be removed from the marked area.

After the welding the entire area is painted with zincspray for corrosion protection and hereafter mounted on the stem. Picture 41.



Fig. 38.



Fig. 39.



Fig. 40.



Fig. 41.

15. Change of gasket sets

Shown example for BROEN Ballomax[®] valves DN10-80 RP.

Part number: 600262.

Step 1:

IMPORTANT: Close the valve before the change of the gaskets is started.

1. Loosen topnut with a spanner or similar.
2. Remove the handle.
3. Take out the pin by means of a hammer and mandrel.

Step 2:

IMPORTANT: Do not leave any marks or scratches on the stem and stem guide.

1. Tip the middle ring up.
2. Put the disassembly tool into the o-ring – backup ring – o-ring and pull them up.

Step 3:

Mount the new gasket set.

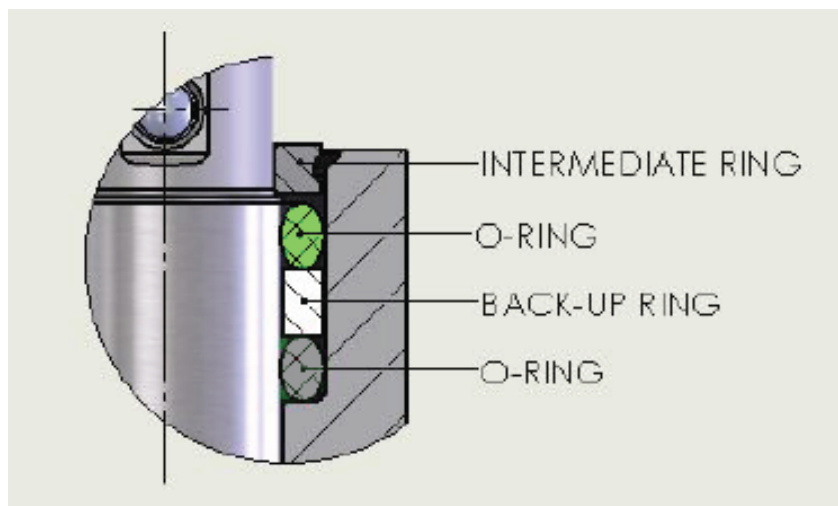
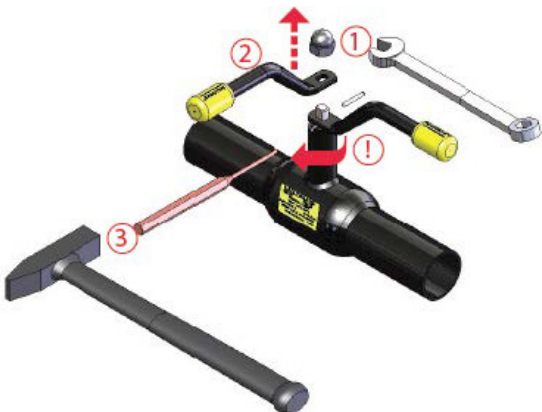

Step 4:

IMPORTANT: Do not squeeze/cut the o-rings on the edge of the stem guide.
Use the supplied mandrel.

1. Carefully put the gasket set in place.



Step 5:

1. Put the pin back in.
2. Put the handle upon the stem.
3. Put on the top nut and tighten lightly.



Step 6:

Open the valve.



Further gasketsets

Without ISO flange:

Size:		Item number:
DN20-80 RB	DN25-65 FB	600262
DN100 RB	DN80 FB	600263
DN125-150 RB	DN100-125 FB	600264
DN200 RB	DN150 FB	600269

With ISO-flange:

Size:		Item number:
DN200 RB		600266
DN250-300 RB	DN200-250 FB	600265
DN400 RB	DN300 FB	600267
DN500 RB	DN400 FB	600268

BROEN Engineered Valve Group

For more than 70 years BROEN has been the global leader in the development and production of valve technology for the control of water, air, gas and oil. BROEN delivers complete solutions for HVAC building installations and is a leading supplier of district energy valves.

We know application and valve technology in depth and in close dialogue with our customers and partners all over the world we create value and reliability with proven valves offering full quality assurance.

BROEN is headquartered in Assens, Denmark and is part of Aalberts Industries NL.

Read more on: www.BROEN.com

BROEN Group locations

Headquarters in Assens, DK

Sales- and productions sites ●

BROEN A/S, Assens (DK)
BROEN SA, Dzierżoniów (PL)
BROEN LLC, Kolomna (RU)
BROEN INC., Houston (US)
BROEN OIL & GAS, Suchy Las & Rogoźno (PL)
BSM Valves B.V., Breda (NL)
Clorius Controls, Dzierżoniów (PL)

Sales companies and offices ○

BROEN, Assens
BROEN, Stockholm
BROEN, Helsinki
BROEN SEI, Romania
BROEN, Beijing
BROEN, Singapore
BROEN, Jakarta
BROEN, Dusseldorf
BROEN, Moscow
Clorius Controls, Copenhagen
Clorius Controls, Shanghai



BROEN A/S

Skovvej 30, DK-5610 Assens, Denmark

Tel. +45 6471 2095 | Fax +45 6471 2495

BROEN@BROEN.com | www.BROEN.com