

www.broen.com

**BROEN**  
VALVE TECHNOLOGIES

# BROEN BALLOMAX® DN 200 - 500

For district heating and district cooling



**BROEN**  
BALLOMAX®

*Designed to last*

## Climate change is our common challenge

Energy efficiency is one of the greatest challenges of our times and for district energy BROEN A/S delivers ready solutions to meet the globally rising demand for energy efficiency.

Based on the heritage from leading edge innovations in Danish district heating, BROEN BALLOMAX® offers the most comprehensive range of proven ball valves for distribution and transmission of district energy in residential, commercial and industrial applications and is today a key component in district heating and district cooling networks throughout the world.

BROEN A/S is ISO 45001:2018, ISO 9001:2015 and ISO 14001:2015 certified.

Our brand is our promise.

### **ABOUT BROEN A/S**

In 1948 Poul Broen established the company BROEN, which was among the pioneers, when district heating took off in Denmark. In 1982 the BROEN BALLOMAX® ball valve for district heating was launched. We strive to develop and improve products, that use nature's resources as efficiently as possible.

### **VISION AND VALUES**

Our vision is simple: Be the best in valve technology. Strong values are the foundation for our business and with the same shared vision they link us together as one company across borders and time zones on 3 continents.

## BROEN BALLOMAX® – our response. Energy efficiency – designed to last!

The BROEN BALLOMAX® DN 200 - 500 features a design optimized for energy efficiency with several flow efficiency enhancing features.

We now set a new standard in energy efficiency, but still deliver the same high BROEN BALLOMAX® quality.

The DN 200 - 500 valves are tested and subjected to a 100% quality control before leaving the factory.

BROEN BALLOMAX® – Designed to last.

**PED 2014/68/EU Module H**  
**EN 12266-I and -II**



BROEN BALLOMAX® high spindle valves have a **triple O-ring** design for enhancing safety.

In addition, a PTFE+C sealing disc is used.

- Optimal flow with increased ball bore diameter!
- New seat construction with reduced torque to operate
- Optimized stem allows for more insulation
- Compact build-in construction
- Efficient Kvs values from modular design with ball flowguide and inlet flow guides

DN 200 - 400 | Full bore | PN 16 - 25 | Flange or weld

DN 250 - 500 | Reduced bore | PN 16 - 25 | Flange or weld

## BROEN BALLOMAX® DN 200 - 500

### Leaping forward in energy efficiency

Optimal flow with increased ball bore diameter and optional ball flow guide and inlet flow guides yield excellent Kvs values. This means reduced investments as the pump and actuation efforts needed to circulate media are reduced with less pressure drop.

Optimized stem and compact construction allows for more insulation.

New seat construction with reduced torque to operate – hence reduced investments and efforts needed and a more efficient operation.

Increased performance with high temperature media.

### Safety – designed to last!

100% safety against stem blow out: Built-in safety construction prevents the risk of a stem blow out.



Kvs optimizing flow guides



Steel ball



Kvs optimizing ball flowguide

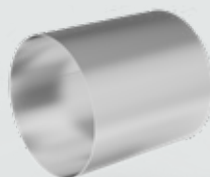

**Low cost of ownership – designed to last!**

ISO 5211 flange.

Exchangeable O-ring on top of stem construction made from FKM and EPDM material in order to avoid entrance of grease and oil.

Robust design built on 30 years of application know-how.

**Easy installation – designed to last!**

Designed to last - Easy installation with minimum maintenance required.

Compact design with compact build-in measures fits in more applications and offers more retrofit opportunities.

- CE PED 2014/68/EU – Module H
- EN 12266-1 and -2
- ISO 5211 flanges



# BROEN BALLOMAX® DN 200 - 500

## Scope of supply



BROEN BALLOMAX®  
Reduced bore | Weld x weld |  
High or low stem.

**Option:**

With ball flowguide and inlet  
flow guides.

DN 250 - 500 PN 25



BROEN BALLOMAX®  
Reduced bore | Flange x flange |  
High or low stem.

**Option:**

With ball flowguide and inlet  
flow guides.

DN 250 - 500 PN 16 and PN 25



BROEN BALLOMAX®  
DN 200 - 500 ball valves  
with optional modular ball  
flowguide and flow optimized  
inlet for superior Kvs values  
and optimized energy  
efficiency.



BROEN BALLOMAX®  
Full bore | Weld x weld |  
High or low stem.

**Standard:**

Ball flowguide.

DN 200 - 400 PN 25



BROEN BALLOMAX®  
Full bore | Flange x flange  
High or low stem.

**Standard:**

Ball flowguide.

DN 200 - 400 PN 16 and PN 25



Together with our compre-  
hensive range of BROEN  
BALLOMAX® gears, BROEN A/S  
offers complete solutions for  
district energy.

# BROEN BALLOMAX® DN 200 - 500

## Product description

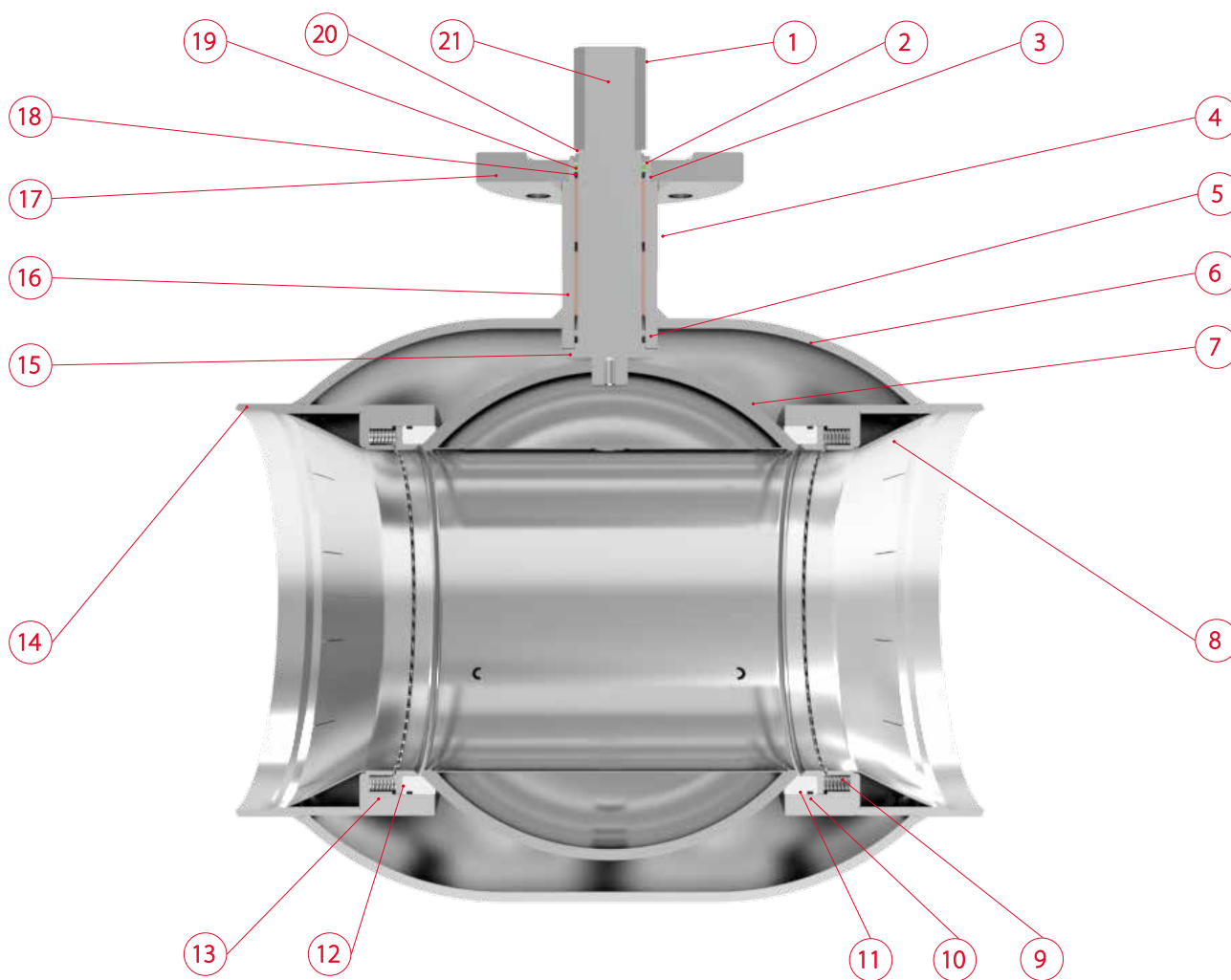

Illustration shows reduced bore value.

No.	Component	Material
1	Parallel key	Steel
2	Circlip DIN471	
3	Back-up ring	PTFE 20% C
4	Stem guide	P235GH - EN10216-2
5	O-ring	AFLAS
6	Valve body	P235GH - EN10217-2
7	Ball 304L	Stainless steel - AISI 304L - 1.4307
8	Flowguides	Steel
9	Springs	AISI 304
10	O-ring	EPDM
11	Seat	PTFE 20% C

No.	Component	Material
12	Back-up ring	S355J2H - EN10210
13	Bottom end	S355J2H - EN10210
14	Weld end	P235GH - EN10028-2
15	Friction ring	Bronze
16	Bearing	PTFE coated steel
17	Flange	EN ISO 5210
18	O-ring	EPDM
19	O-ring	FPM
20	Back-up ring	PTFE 20% C
21	Stem	Stainless steel - ASTM 420 - 1.4021

# BROEN BALLOMAX® DN 200 - 500

## Stem seal

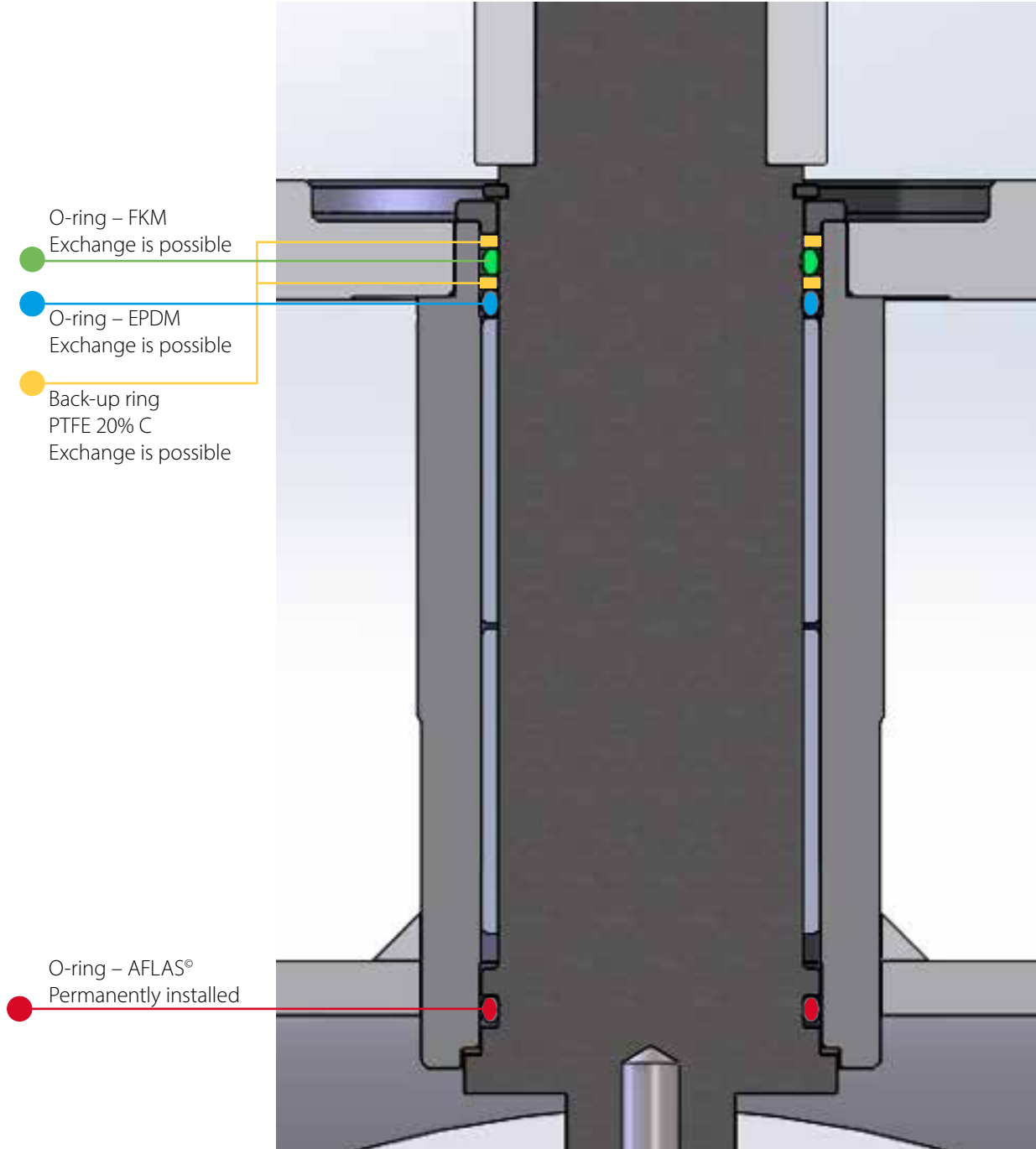

- EPDM
- AFLAS®
- FKM
- PTFE 20% C

# BROEN BALLOMAX® DN 200 - 500

## Technical data

Material, valve housing:	P235GH / EN 10217-2
Sizes:	DN 200 - 400 FB + DN 250 - 500 RB
Seals:	PTFE 20% C (Polytetrafluorethylene)
O-rings:	AFLAS®, EPDM + FKM
Medium:	Water
Operating pressure:	Max 25 bar
Operating temperature:	-20°C to +150°C
Design temperature:	-20°C to +200°C

### Kvs values - Full bore

DN [mm]	200	250	300	400
Kvs [m3/h]	9200	13500	21600	35000

### Kvs values - Reduced bore

DN [mm]	250	300	350	400	500
Kvs [m3/h]	3200	4700	5500	10600	18150

### Kvs values - Reduced bore - Flowoptimized

DN [mm]	250	300	350	400	500
Kvs [m3/h]	5300	8200	8900	13700	20300

## Pressure and temperature diagram

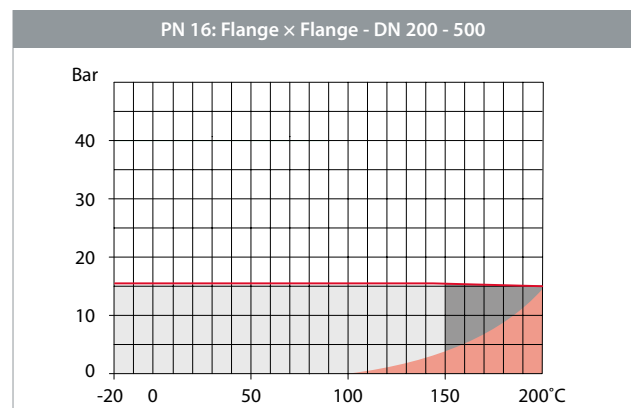
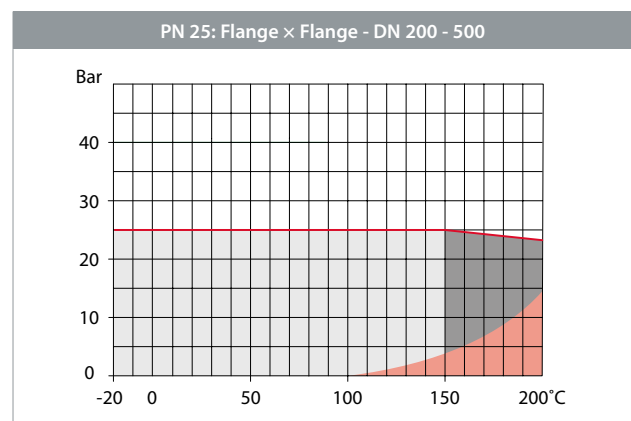
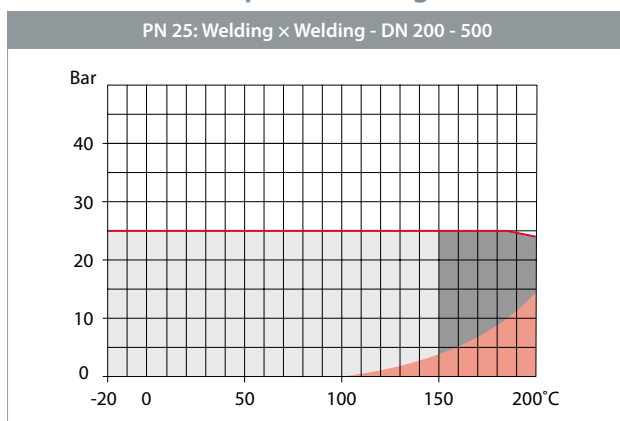

- Normal working area
- Short-term working area
- Steam area

## BROEN BALLOMAX® DN 250 - 500, PN 25

Weldings | Reduced bore | High spindle

**FLOWOPTIMIZED**

Triple  
O-ring  
design

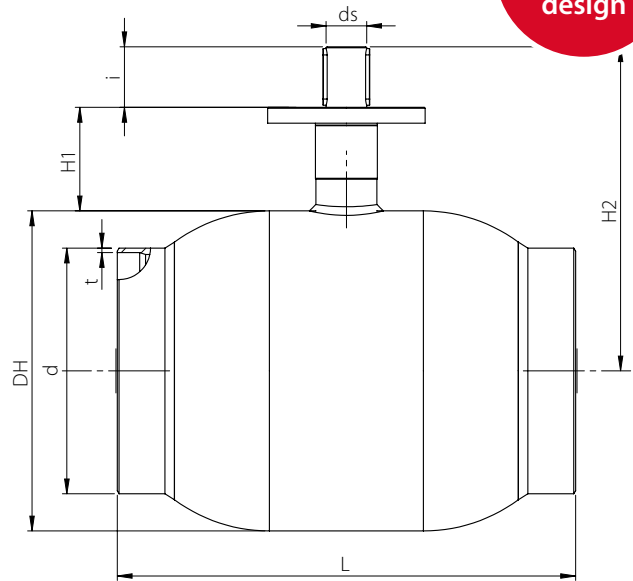

Reduced bore - with inlet flow guides						All dimensions in mm								
DN	BROEN no.	Bore $\phi$ mm	Kvs in $\text{m}^3/\text{h}$	PN	Net weight in Kg	DH	d	t	L	H1	H2	ds	i	ISO
250	8511225250 000	200	5.300	25	69,8	356	273,0	5,0	509	115	360,0	45	67	F14
300	8511225300 000	250	8.200	25	111,7	457	323,9	5,6	586	130	443,0	50	84	F16
350	8511225350 000	250	8.900	25	130,5	457	355,6	5,6	662	130	443,0	50	84	F16
400	8511225400 000	305	13.700	25	194,1	508	406,4	6,3	736	155	506,5	60	100	F16
500	8511225500 000	400	20.300	25	377,0	660	508,0	6,3	889	180	622,0	80	112	F30

Flowoptimized - with in- and outlet sleeves for improved kv value.

# BROEN BALLOMAX® DN 250 - 500, PN 25

Weldings | Reduced bore | High spindle

FLOWOPTIMIZED

Triple  
O-ring  
design

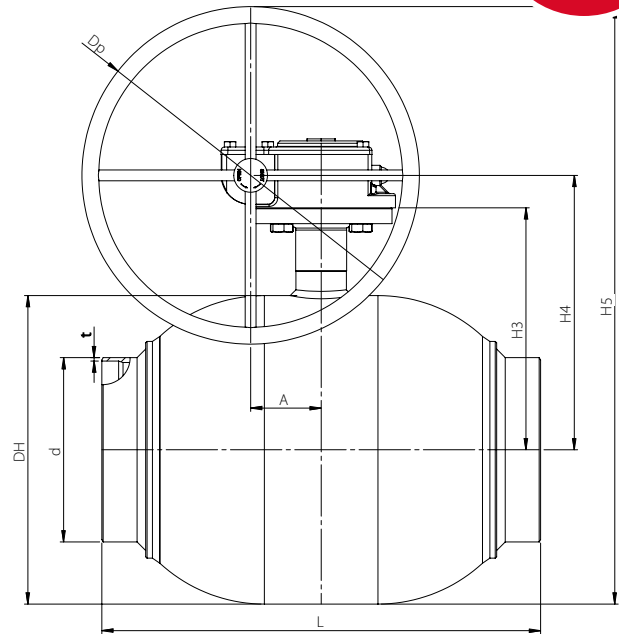

Reduced bore - with inlet flow guides						All dimensions in mm								
DN	BROEN no.	Bore ø mm	Kvs in m <sup>3</sup> /h	PN	Net weight in Kg	DH	d	t	L	H3	H4	H5	Dp	A
250	8513225250 480	200	5.300	25	71,9	356	273,0	5,0	509	293	330	733	450	68,8
300	8513225300 480	250	8.200	25	116,6	457	323,9	5,6	586	359	407	885	500	104,5
350	8513225350 480	250	8.900	25	135,4	457	355,6	5,6	662	359	407	885	500	104,5
400	8513225400 480	305	13.700	25	222,8	508	406,4	6,3	736	410	464	894	350	130,0
500	8513225500 480	400	20.300	25	416,2	660	508,0	6,3	889	510	569	1124	450	182,0

Flowoptimized - with in- and outlet sleeves for improved kv value.

Valve with gear is tested and prepared for use.

# BROEN BALLOMAX® DN 200 - 500, PN 25

Weldings | Full bore or reduced bore | High spindle

Triple  
O-ring  
design

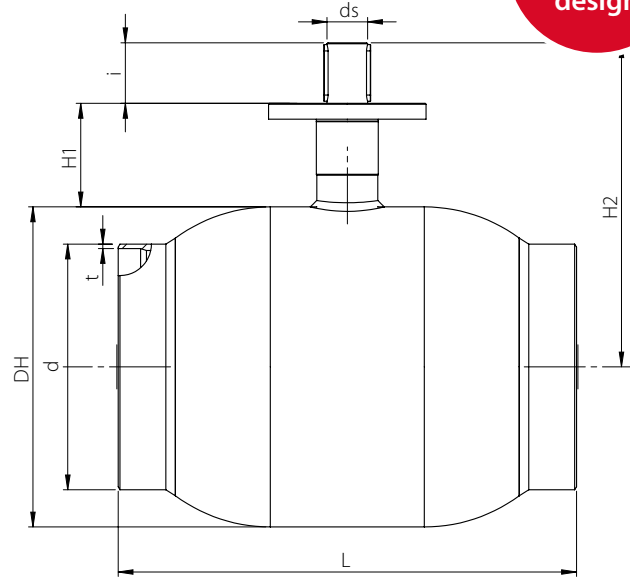

Full bore - Reduced bore - with inlet flow guides						All dimensions in mm								
DN	BROEN no.	Bore $\phi$ mm	Kvs in $m^3/h$	PN	Net weight in Kg	DH	d	t	L	H1	H2	ds	i	ISO
200	8621225200 000	200	9.200	25	83,7	356	219,1	5,0	533	115	365,0	45	67	F14
250	8621225250 000	250	13.500	25	137,5	457	273,0	5,0	650	130	442,5	50	84	F16
300	8601225300 000	305	21.600	25	215,3	508	323,9	5,6	819	155	506,5	60	100	F16
400	8601225400 000	400	35.000	25	419,2	660	406,4	6,3	991	180	622,4	80	112	F30

Reduced bore						All dimensions in mm								
DN	BROEN no.	Bore $\phi$ mm	Kvs in $m^3/h$	PN	Net weight in Kg	DH	d	t	L	H1	H2	ds	i	ISO
250	8501225250 000	200	3.200	25	68,0	356	273,0	5,0	509	115	349,8	45	67	F14
300	8501225300 000	250	4.700	25	108,9	457	323,9	5,6	586	130	443,0	50	84	F16
350	8501225350 000	250	5.500	25	127,8	457	355,6	5,6	662	130	443,0	50	84	F16
400	8501225400 000*	305	10.600	25	192,2	508	406,4	6,3	736	155	506,5	60	100	F16
500	8501225500 000*	400	18.150	25	374,0	660	508,0	6,3	889	180	622,0	80	112	F30

\* DN 400 - 500 - with ball flowguide.

# BROEN BALLOMAX® DN 200 - 500, PN 25

Weldings | Full bore or reduced bore | High spindle

Triple  
O-ring  
design

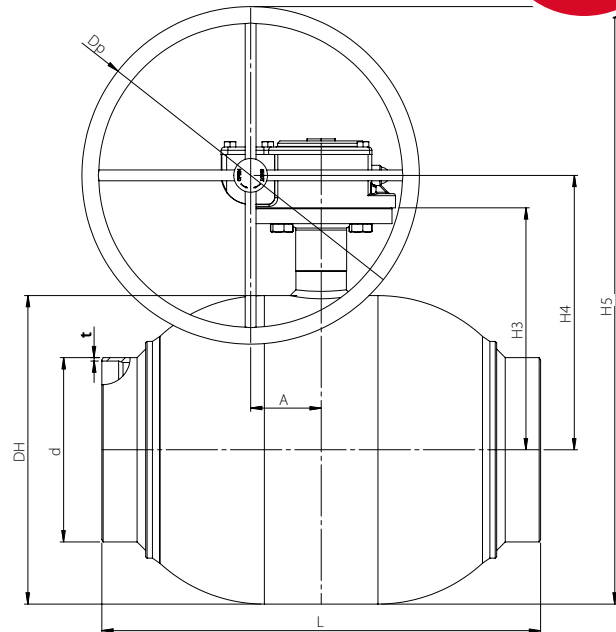

Full bore - Reduced bore - with inlet flow guides						All dimensions in mm								
DN	BROEN no.	Bore $\phi$ mm	Kvs in $m^3/h$	PN	Net weight in Kg	DH	d	t	L	H3	H4	H5	dp	A
200	8623225200 480	200	9.200	25	85,8	356	219,1	5,0	533	293	330	734	450	68,8
250	8623225250 480	250	13.500	25	142,4	457	273,0	5,0	650	359	407	886	500	104,5
300	8603225300 480	305	21.600	25	257,4	508	323,9	5,6	819	410	465	894	350	130,0
400	8603225400 480	400	35.000	25	487,3	660	406,4	6,3	991	510	569	1124	450	182,0

Reduced bore						All dimensions in mm								
DN	BROEN no.	Bore $\phi$ mm	Kvs in $m^3/h$	PN	Net weight in Kg	DH	d	t	L	H3	H4	H5	dp	A
250	8503225250 480	200	3.200	25	70,1	356	273,0	5,0	509	293	330	733	450	68,8
300	8503225300 480	250	4.700	25	114,0	457	323,9	5,6	586	359	407	885	500	104,5
350	8503225350 480	250	5.500	25	132,7	457	355,6	5,6	662	359	407	885	500	104,5
400	8503225400 480	305	10.600	25	221,0	508	406,4	6,3	736	410	464	894	350	130,0
500	8503225500 480	400	18.150	25	413,3	660	508,0	6,3	889	510	569	1124	450	182,0

Valve with gear is tested and prepared for use.

# BROEN BALLOMAX® DN 250 - 500, PN 16 & 25

Flanges | Reduced bore | High spindle

**FLOWOPTIMIZED**

Triple  
O-ring  
design

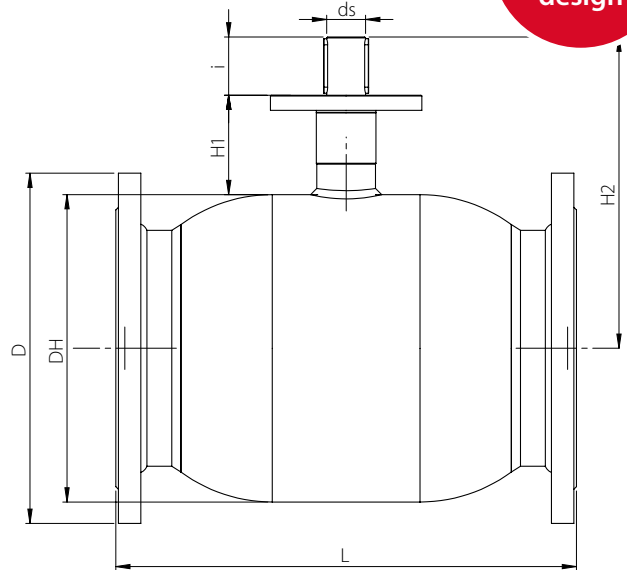

Reduced bore - with inlet flow guides						All dimensions in mm							
DN	BROEN no.	Bore ø mm	Kvs in m <sup>3</sup> /h	PN	Net weight in Kg	DH	D	L	H1	H2	ds	i	ISO
250	8511416250 000	200	5.300	16	92,2	356	405	533	115	360,0	45	67	F14
300	8511416300 000	250	8.200	16	146,7	457	460	610	130	443,0	50	84	F16
350	8511416350 000	250	8.900	16	184,1	457	520	686	130	443,0	50	84	F16
400	8511416400 000	305	13.700	16	249,9	508	620	762	155	506,5	60	100	F16
500	8511416500 000	400	20.300	16	472,3	660	715	914	180	622,0	80	112	F30

Reduced bore - with inlet flow guides						All dimensions in mm							
DN	BROEN no.	Bore ø mm	Kvs in m <sup>3</sup> /h	PN	Net weight in Kg	DH	D	L	H1	H2	ds	i	ISO
250	8511425250 000	200	5.300	25	108,6	356	425	533	115	360,0	45	67	F14
300	8511425300 000	250	8.200	25	162,7	457	485	610	130	443,0	50	84	F16
350	8511425350 000	250	8.900	25	211,1	457	555	686	130	443,0	50	84	F16
400	8511425400 000	305	13.700	25	302,9	508	620	762	155	506,5	60	100	F16
500	8511425500 000	400	20.300	25	543,6	660	730	914	180	622,0	80	112	F30

Flowoptimized - with in- and outlet sleeves for improved kv value.

# BROEN BALLOMAX® DN 250 - 500, PN 16 & 25

Flanges | Reduced bore | High spindle

FLOWOPTIMIZED

Triple  
O-ring  
design

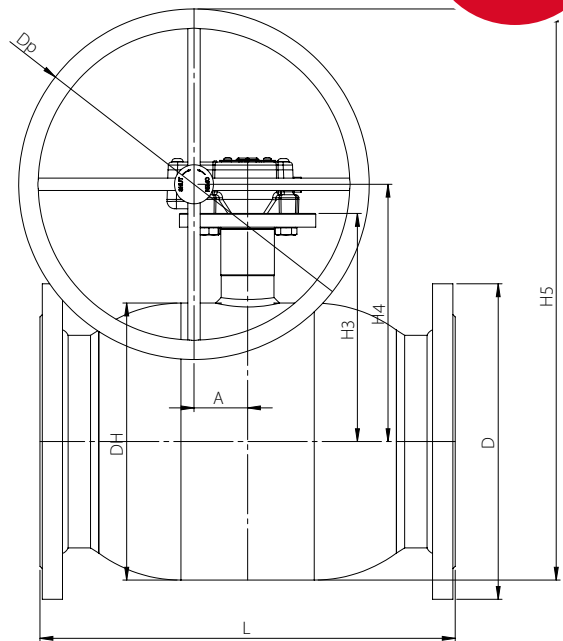

Reduced bore - with inlet flow guides						All dimensions in mm							
DN	BROEN no.	Bore ø mm	Kvs in m <sup>3</sup> /h	PN	Net weight in Kg	DH	D	L	H3	H4	H5	Dp	A
250	8513416250 480	200	5.300	16	98,3	356	405	533	293	330	733	450	68,8
300	8513416300 480	250	8.200	16	151,7	457	460	610	359	407	885	500	104,5
350	8513416350 480	250	8.900	16	188,5	457	520	686	359	407	885	500	104,5
400	8513416400 480	305	13.700	16	292,0	508	620	762	410	464	894	350	130,0
500	8513416500 480	400	20.300	16	540,4	660	730	914	510	569	1124	450	182,0

Reduced bore - with inlet flow guides						All dimensions in mm							
DN	BROEN no.	Bore ø mm	Kvs in m <sup>3</sup> /h	PN	Net weight in Kg	DH	D	L	H3	H4	H5	Dp	A
250	8513425250 480	200	5.300	25	110,7	356	405	533	293	330	733	450	68,8
300	8513425300 480	250	8.200	25	167,6	457	460	610	359	407	885	500	104,5
350	8513425350 480	250	8.900	25	215,4	457	555	686	359	407	885	500	104,5
400	8513425400 480	305	13.700	25	332,5	508	620	762	410	464	894	350	130,0
500	8513425500 480	400	20.300	25	583,4	660	730	914	510	569	1124	450	182,0

Flowoptimized - with in- and outlet sleeves for improved kv value.

Valve with gear is tested and prepared for use.

# BROEN BALLOMAX® DN 200 - 500, PN 16

Flanges | Full bore or reduced bore | High spindle

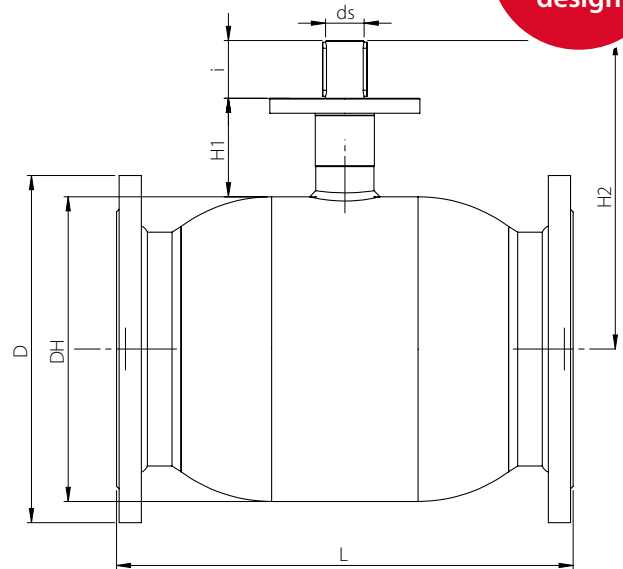

Triple  
O-ring  
design

Full bore - with inlet flow guides						All dimensions in mm							
DN	BROEN no.	Bore ø mm	Kvs in m <sup>3</sup> /h	PN	Net weight in Kg	DH	D	L	H1	H2	ds	i	ISO
200	8621416200 000	200	9.200	16	102,9	356	340	550	115	360	45	67	F14
250	8621416250 000	250	13.500	16	163,9	457	405	673	130	386	50	84	F16
300	8601416300 000	305	21.600	16	250,4	508	460	850	155	507	60	100	F16
400	8601416400 000	400	35.000	16	486,9	660	580	1016	180	527	80	112	F30

Reduced bore						All dimensions in mm							
DN	BROEN no.	Bore ø mm	Kvs in m <sup>3</sup> /h	PN	Net weight in Kg	DH	D	L	H1	H2	ds	i	ISO
250	8501416250 000	200	3.200	16	94,4	356	405	533	115	360,0	45	67	F14
300	8501416300 000	250	4.700	16	143,9	457	460	610	130	443,0	50	84	F16
350	8501416350 000	250	5.500	16	180,8	457	520	686	130	443,0	50	84	F16
400	8501416400 000*	305	10.600	16	248,1	508	620	762	155	506,5	60	100	F16
500	8501416500 000*	400	18.150	16	469,4	660	730	914	180	622,5	80	112	F30

\* DN 400 - 500 - with ball flowguide.

# BROEN BALLOMAX® DN 200 - 500, PN 16

Flanges | Full bore or reduced bore | High spindle

Triple  
O-ring  
design

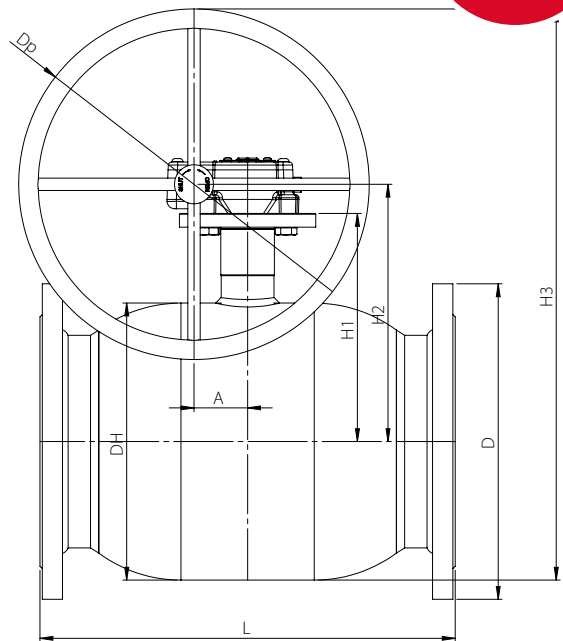

Full bore - with inlet flow guides						All dimensions in mm							
DN	BROEN no.	Bore ø mm	Kvs in m <sup>3</sup> /h	PN	Net weight in Kg	DH	D	L	H1	H2	H3	Dp	A
200	8623416200 480	200	9.200	16	105,0	356	340	550	293	330	734	450	68,8
250	8623416250 480	250	13.500	16	168,9	457	405	673	359	407	886	500	104,5
300	8603416300 480	305	21.600	16	292,5	508	460	850	410	465	894	350	130,0
400	8603416400 480	400	35.000	16	555,0	660	580	1016	510	569	1124	450	182,0

Reduced bore						All dimensions in mm							
DN	BROEN no.	Bore ø mm	Kvs in m <sup>3</sup> /h	PN	Net weight in Kg	DH	D	L	H1	H2	H3	Dp	A
250	8503416250 480	200	3.200	16	96,5	356	405	533	293	330	733	450	68,8
300	8503416300 480	250	4.700	16	149,1	457	460	610	359	407	885	500	104,5
350	8503416350 480	250	5.500	16	185,8	457	520	686	359	407	885	500	104,5
400	8503416400 480	305	10.600	16	290,1	508	620	762	410	464	894	350	130,0
500	8503416500 480	400	18.150	16	537,5	660	730	914	510	569	1124	450	182,0

Valve with gear is tested and prepared for use.

## BROEN BALLOMAX® DN 200 - 500, PN 25

Flanges | Full bore or reduced bore | High spindle

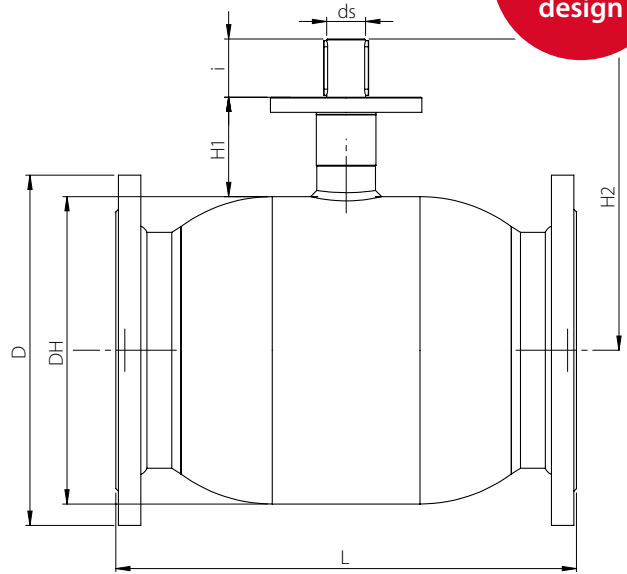

Triple  
O-ring  
design

Full bore - with inlet flow guides						All dimensions in mm							
DN	BROEN no.	Bore $\phi$ mm	Kvs in $m^3/h$	PN	Net weight in Kg	DH	D	L	H1	H2	ds	i	ISO
200	8621425200 000	200	9.200	25	111,1	356	360	550	115	360	45	67	F14
250	8621425250 000	250	13.500	25	176,2	457	425	673	130	386	50	84	F16
300	8601425250 000	305	21.600	25	265,4	508	485	850	155	507	60	100	F16
400	8601425400 000	400	35.000	25	528,8	660	620	1016	180	527	80	112	F30

Reduced bore						All dimensions in mm							
DN	BROEN no.	Bore $\phi$ mm	Kvs in $m^3/h$	PN	Net weight in Kg	DH	D	L	H1	H2	ds	i	ISO
250	8501425250 000	200	3.200	25	106,7	356	425	533	115	360,0	45	67	F14
300	8501425300 000	250	4.700	25	160,1	457	485	610	130	443,0	50	84	F16
350	8501425350 000	250	5.500	25	207,8	457	555	686	130	443,0	50	84	F16
400	8501425400 000	305	10.600	25	301,1	508	620	762	155	506,5	60	100	F16
500	8501425500 000	400	18.150	25	541,2	660	730	914	180	622,5	80	112	F30

\* DN 400 - 500 - with ball flowguide.

# BROEN BALLOMAX® DN 200 - 500, PN 25

Flanges | Full bore or reduced bore g | High spindle

Triple  
O-ring  
design

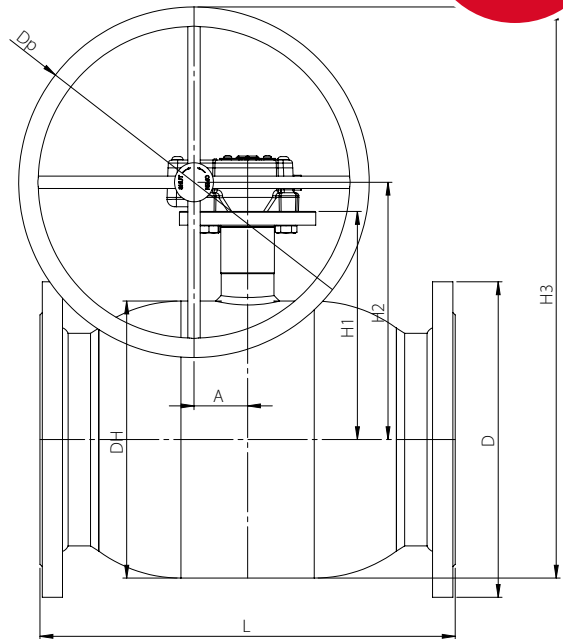

Full bore - with inlet flow guides						All dimensions in mm							
DN	BROEN no.	Bore ø mm	Kvs in m <sup>3</sup> /h	PN	Net weight in Kg	DH	D	L	H1	H2	H3	Dp	A
200	8623425200 480	200	9.200	25	113,2	356	360	550	293	330	734	450	68,8
250	8623425250 480	250	13.500	25	181,2	457	425	673	359	407	886	500	104,5
300	8603425300 480	305	21.600	25	307,4	508	485	850	410	465	894	350	130,0
400	8603425400 480	400	35.000	25	597,0	660	620	1016	510	569	1124	450	182,0

Reduced bore						All dimensions in mm							
DN	BROEN no.	Bore ø mm	Kvs in m <sup>3</sup> /h	PN	Net weight in Kg	DH	D	L	H1	H2	H3	Dp	A
250	8503425250 480	200	3.200	25	108,8	356	405	533	293	330	733	450	68,8
300	8503425300 480	250	4.700	25	165,0	457	460	610	359	407	885	500	104,5
350	8503425350 480	250	5.500	25	212,2	457	520	686	359	407	885	500	104,5
400	8503425400 480	305	10.600	25	330,6	508	620	762	410	464	894	350	130,0
500	8503425500 480	400	18.150	25	580,5	660	730	914	510	569	1124	450	182,0

Valve with gear is tested and prepared for use.

*Our brand is our promise*

**BROEN**  
VALVE TECHNOLOGIES

## **BROEN Valve Technologies**

BROEN is a leading international manufacturer of valve technology and we operate on three continents across the world with key markets in Europe, China and USA.

For more than 75 years BROEN has been the global leader in the development and production of valve technology for the control of water, air and gas. BROEN delivers complete solutions for HVAC building installations and is a leading supplier of district energy valves and valve technology for natural gas.

We know application and valve technology in depth and in close dialogue with our customers and partners all over the world we create value and reliability with proven valves offering full quality assurance.

Read more at: [www.broen.com](http://www.broen.com)

### **Sales- and productions sites ●**

BROEN A/S, Assens (DK)  
BROEN POLAND, Dzierżoniów (PL)  
BROEN POLAND, Rogoźno (PL)  
BROEN INC., Houston (US)  
BROEN Clorius, Dzierżoniów (PL)

### **Sales companies and offices ○**

BROEN Assens (DK)  
BROEN Helsinki (FI)  
BROEN SEI, Bucharest (RO)  
BROEN Beijing (CN)  
BROEN Clorius, Shanghai (CN)

